

Research Article

# Compound Parabolic Concentrators as Solar Trackers

Gayatri Shahane<sup>+</sup>, Ayushi Jain<sup>‡</sup>, Sneha Ugale<sup>†</sup> and C.P. Waykole<sup>^</sup>

<sup>+</sup>Department of Mechanical Engineering, Savitribai Phule Pune University, R.H. 47/48 Sankul Erandawana Pune 411004 India

<sup>‡</sup>Department of Mechanical Engineering, Savitribai Phule Pune University, A-1102, Riviera, Hiranandani Estate, Thane 400607, India

<sup>†</sup>Department of Mechanical Engineering, Savitribai Phule Pune University, Sneh, Govind Nagar, Ambejogai Road, Latur 413512, India

<sup>^</sup>Department of Mechanical Engineering, Savitribai Phule Pune University, Flat No. 513, Ganesh Nakshatra, DSK Vishwa Rd, Dhayari 411041, India

Accepted 12 March 2017, Available online 16 March 2017, **Special Issue-7 (March 2017)**

## Abstract

*This paper gives an overview of the existing solar tracking systems, their benefits and outcomes. It further discusses the disadvantages of solar trackers and suggests Compound Parabolic Concentrators as a viable option for tracking. Solar trackers are used to ensure that the solar panel is at a perpendicular with the sun, so that it maximizes the energy falling on it. Compound Parabolic Concentrator (CPC) is a special type of solar collector designed in the shape of two meeting parabolas.*

**Keywords:** Solar Tracking, Compound Parabolic Concentrator, CPC.

## 1. Introduction

There is abundance of incident solar energy but only a small part of it is being harnessed. The earth gets 174000 Terawatts of incoming solar radiation in the upper atmosphere. About 30% is reflected back to space and the rest is absorbed by oceans, clouds and land masses. In 2013, total world energy consumption was equal to an average power consumption of 12.3 Terawatts. Due to the apparent energy crisis and need for green energy there is growing demand for solar energy harnessing techniques. Solar energy is not only a renewable source but also is non-polluting, abundantly available and free. Solar panels are most widely used to harness solar energy. Because of the changing sun position with respect to earth's axis solar tracking is necessary for the panels, to maximize their efficiency.

## 2. Solar Tracking

### 2.1 Introduction to Solar Tracking

In today's time the solar cells are most popularly used for harnessing solar energy to use in different ways like storing energy in batteries, heating water, transportation etc. Hence, many solar panels have been installed for industrial as well as household use. But due to the movement of the earth around the sun, the sun position keeps changing with respect to time of the day as well as time of the year. So, in order to receive

maximum solar radiation the position of the solar panels also needs to be adjusted accordingly i.e. solar trackers are required for maximum efficiency.

The efficiency of the solar panel increases when we constantly modify its angle with respect to the sun angles. The increase in output of electricity can be upto 30% due to solar tracking. Thus the use of solar tracking devices makes a significant difference in big solar plants.

The sun's position keeps changing throughout the day as well as the year. Thus there are two types of solar trackers based on the type of tracking.

- 1) Single Axis Solar Tracker
- 2) Dual Axis Solar Tracker

### 2.2 Single Axis Solar Tracker

Single axis solar trackers can rotate the solar panels only about one axis. The tracking can be done along either North-South axis or East-West axis. For seasonal tracking of the sun, the solar panel rotates about the East-West axis. Whereas for daily tracking, the solar panel rotates about the North-South axis.

### 2.3 Dual Axis Solar Tracker

Dual axis solar trackers can rotate the solar panels about two axes simultaneously. The tracking can be done along both North-South and East-West axes. Dual axis solar tracker does seasonal as well as daily tracking which increases the efficiency of the plant by approximately 30%.

\*Corresponding author: **Gayatri Shahane**

### 2.4 Disadvantages of Solar Trackers

The initial investment of solar trackers is high due to its requirement of applying complex mechanisms.

Its operating cost is high because regular maintenance of moving parts is essential and it usually needs electricity for its working.

Highly efficient solar tracking systems use sophisticated and complicated software and electronics.

Solar trackers are usually designed for climates with little to no snow. They cannot sustain harsh weather conditions

## 3. Compound Parabolic Concentrators

### 3.1 Introduction to Compound Parabolic Concentrators

Compound Parabolic Concentrator (CPC) is a special type of solar collector designed in the shape of two meeting parabolas. By combining two parabolas together, it forms a Compound Parabolic Trough Solar Collector. The co-focal point then becomes a co-focal line. Such a solar collector does not need tracking, and require only occasional season angle adjustments.. It concentrates a large amount of sunlight in small area with minimum loses.

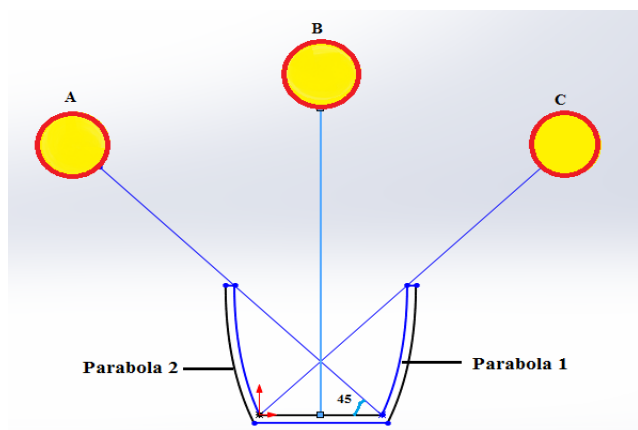

Fig.1 CPC with Sun Positions

The above figure (Fig.1) shows the CPC with sun positions. The CPC starts functioning at position A (at 45° left from axis) and ends at C (at 45° right from the axis), assuming the CPC is kept facing East-West. Acceptance angle is the limiting angle over which incident ray path may deviate from normal to the aperture plane and still reach the absorber. In Fig.1 the acceptance angle is shown to be 45°. The CPC absorbs the sun radiation in the range of the acceptance angle. Hence, it does not need day tracking of sun and only need occasional seasonal adjustments.

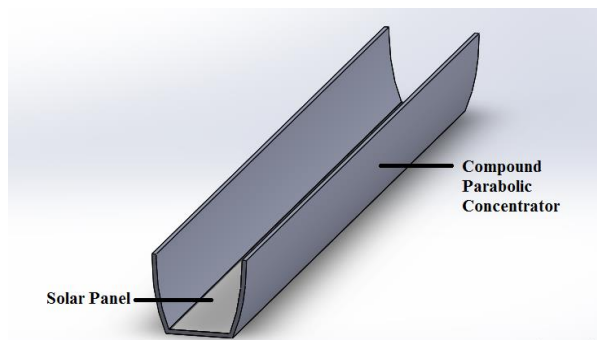

Fig.2 Model of CPC with Solar Panels

The above figure (Fig.2) shows a SolidWorks model of a Compound Parabolic Concentrator and a Solar Panel between it.

### 3.2 Advantages of Compound Parabolic Concentrators over Solar Trackers

CPCs are not complex to design and implement unlike the solar trackers.

They do not consume electricity for tracking.

They need less or no maintenance.

They are reliable and have a long life.

They can be used in all weathers like snow, summers and even rains.

## Conclusions

- Solar trackers are extensively used everywhere around the world for maximizing the efficiency of the solar panels.
- Compound Parabolic Concentrators are an also an effective way for concentrating as well as tracking the sun for capturing increased radiation.
- Compound Parabolic Concentrators can be considered as a viable option instead of solar trackers.

## References

Key World Energy Statistics 2015 (PDF). www.iea.org. IEA. 2015. pp. 8, 37. Archived from the original on 13 March 2015.

Reshmi Banerjee (2015), Solar Tracking System, International Journal of Scientific and Research Publications, Volume 5, Issue 3, March 2015  
<http://www.solarpowerworldonline.com/2016/05/advantages-disadvantages-solar-tracker-system/>

Gayatri Shahane (2017), Solar Desalination using CPC and Heat Pipe, International Advanced Research Journal in Science, Engineering and Technology, Volume 4, Issue 1, January 2017

OPTIS White Paper 1008 Solar CPC