

Research Article

# Studies on Exhaust Emissions and Combustion Characteristics of Di Diesel Engine with Air Gap Insulation with Varied Injection Timing and Injector Opening Pressure

N. Janardhan<sup>†</sup>, M.V.S. Murali Krishna<sup>†\*</sup>, Ch. Kesava Reddy<sup>‡</sup> and N. Durga Prasada Rao<sup>†</sup> and L.Suresh Kumar<sup>†</sup>

<sup>†</sup>Mechanical Engineering Department, Chaitanya Bharathi Institute of Technology, Gandipet, Hyderabad 500 075, Telangana State, India

<sup>‡</sup>Research Scholar, Mechanical Engineering, Rayalaseema University, Karnool- 518502, Andhra Pradesh, India

<sup>†</sup>Bharat Dynamics Limited, Hyderabad, India

Accepted 10 Jan 2016, Available online 13 Jan 2016, Vol.6, No.1 (Feb 2016)

## Abstract

Experiments were carried out to study exhaust emissions and combustion characteristics of diesel engine with air gap insulated low heat rejection (LHR-2) combustion chamber consisting of air gap insulated piston with 3 mm air gap, with superni (an alloy of nickel) crown, air gap insulated liner with superni insert with neat diesel with varied injection timing and injector opening pressure. Exhaust emissions of particulate emissions and nitrogen oxide (NO<sub>x</sub>) levels were determined at various values of brake mean effective pressure (BMEP) of the LHR-2 combustion chamber and compared with neat diesel operation on conventional engine (CE) at similar operating conditions. Combustion diagnosis was carried out using miniature Piezo electric pressure transducer, TDC (top dead centre) and special pressure-crank angle software package at full load operation. The optimum injection timing was found to be 31° bTDC (before top dead centre) with conventional engine, while it was 29° bTDC for engine with LHR-2 combustion chamber with diesel operation. Engine with LHR-2 combustion chamber with neat diesel operation showed increased particulate emissions and NO<sub>x</sub> levels at manufacturer's recommended injection timing of 27° bTDC, and they improved marginally with advanced injection timing of 29° bTDC in comparison with CE at 27° bTDC.

**Keywords:** Conservation of diesel, conventional engine, LHR combustion chamber, exhaust emissions and combustion characteristics

## Introduction

In the scenario of i) increase of vehicle population at an alarming rate due to advancement of civilization, ii) use of diesel fuel in not only transport sector but also in agriculture sector leading to fast depletion of diesel fuels and iii) increase of fuel prices in International market leading to burden on economic sector of Govt. of India, conservation of diesel fuel has become pertinent for the engine manufacturers, users and researchers involved in the combustion research. [Matthias Lamping *et al*, 2008].

The nation should pay gratitude towards Dr. Diesel for his remarkable invention of diesel engine. Compression ignition (CI) engines, due to their excellent fuel efficiency and durability, have become popular power plants for automotive applications. This is globally the most accepted type of internal combustion engine used for powering agricultural implements, industrial applications, and construction equipment along with marine propulsion. [C. Cummins, *et al*, 1993; Avinash Kumar Agarwal *et al*, 2013].

The concept of LHR combustion chamber is to reduce coolant losses by providing thermal resistance in the path of heat flow to the coolant, there by gaining thermal efficiency. Several methods adopted for achieving LHR to the coolant are ceramic coated engines and air gap insulated engines with creating air gap in the piston and other components with low-thermal conductivity materials like superni, cast iron and mild steel etc.

LHR combustion chambers were classified as ceramic coated (LHR-1), air gap insulated (LHR-2) and combination of ceramic coated and air gap insulated engines(LHR-3) combustion chambers depending on degree of insulations.

Wallace *et al.* also studied the performance of the insulated piston engine in which air gap thickness was maintained at 2-mm. [F.J.Wallace *et al*, 1983]. The major finding was increase of particulate emissions due to reduction of air-fuel ratios from 18.27 to astonishingly small 12.76, which was inadmissible in practice.

Karthikeyan *et al.* studied the performance of a diesel engine by insulating engine parts employing 2-mm air gap in the piston and the liner, thus attaining a

\*Corresponding author: M.V.S. Murali Krishna

semi-adiabatic condition. [S. Karthikeyan et al, 1985]. The nimonic piston with 2-mm air gap was studded with the body of the piston. Mild steel sleeve, provided with 2-mm air gap was fitted with the total length of the liner. They reported increase of particulate emissions at all loads, when compared to neat diesel operation on conventional engine. This was due to higher exhaust gas temperatures.

Jabez Dhinagar et al. conducted experiments on LHR engine, with an air gap insulated piston, air gap insulated liner and ceramic coated cylinder head. [S.Dhinagar et al, 1989]. The piston with nimonic crown with 2 mm air gap was fitted with the body of the piston by stud design. Mild steel sleeve was provided with 2 mm air gap and it was fitted with the 50 mm length of the liner. The performance was deteriorated with this engine and increase of particulate emissions at full load operation with neat diesel operation, at recommended injection timing. Hence the injection timing was retarded to improve performance and pollution levels.

The technique of providing an air gap in the piston involved the complications of joining two different metals. Investigations were carried out on LHR-2 combustion chamber- with air gap insulated piston with pure diesel [D.A. Parker et al, 1987]. However, the bolted design employed by them could not provide complete sealing of air in the air gap. Investigations were carried out with engine with LHR-2 combustion chamber with air gap insulated piston with nimonic crown threaded with the body of the piston fuelled with neat diesel with varied injection timing.[K. Ramamohan et al, 1999]. They reported from their investigations that particulate emissions and NO<sub>x</sub> levels decreased and improved combustion characteristics with advanced injection timing of 29.5° bTDC Engine with LHR combustion chamber was more suitable for vegetable oil operation, as hot combustion chamber was maintained by it in burning high viscous vegetable oils. Experiments were conducted on engine with LHR-2 combustion chamber with varied injection timing and injection pressure. [C.M. Vara Prasad et al, 2000; M.V.S. Murali Krishna et al, 2004; Chennakesava Reddy et al, 2011; N.Janardhan et al, 2012; M.V.S .Murali Krishna et al, 2013; D. Srikanth et al, 2013]. They reported from their investigations that engine with LHR-2 combustion chamber decreased particulate emissions by 8–10% in comparison with neat diesel operation on CE. Exhaust emissions and combustion characteristics were improved with advanced injection timing. Investigations were carried out on single cylinder diesel engine with 3.68 kW brake power with LHR-2 combustion chamber with varied injection timing. [N. Janardhan et al, 2014; N.Janardhan et al, 2015; N.Janardhan et al, 2015; N.Janardhan et al, 2015]. They reported that LHR-2 engine with diesel improved efficiency marginally and reduced particulate emissions marginally and increased nitrogen oxide levels drastically. However, they maintained injector opening pressure constant throughout the experiment.

The present paper attempted to study exhaust emissions and combustion characteristics of medium grade LHR combustion chamber, which consisted of air gap insulated piston and air gap insulated liner. This medium grade LHR-2 combustion chamber was fuelled with diesel fuel with varied injection timing and injector opening pressure. Comparative performance studies were made with conventional engine with diesel operation.

**Materials and Methods**

This part deals with fabrication of air gap insulated piston and air gap insulated liner, brief description of experimental set-up, specification of experimental engine, operating conditions and definitions of used values.

The physic-chemical properties of the diesel fuel are presented in Table-1.

**Table.1** Properties of Diesel

Property	Units	Diesel
Carbon chain	--	C <sub>8</sub> -C <sub>28</sub>
Cetane Number		55
Density	gm/cc	0.84
Bulk modulus @ 20Mpa	Mpa	1475
Kinematic viscosity @ 40°C	cSt	2.25
Sulfur	%	0.25
Oxygen	%	0.3
Air fuel ratio ( stoichiometric)	--	14.86
Lower calorific value	kJ/kg	44800
Flash point (Open cup)	°C	68
Molecular weight	--	226
Colour	--	Light yellow

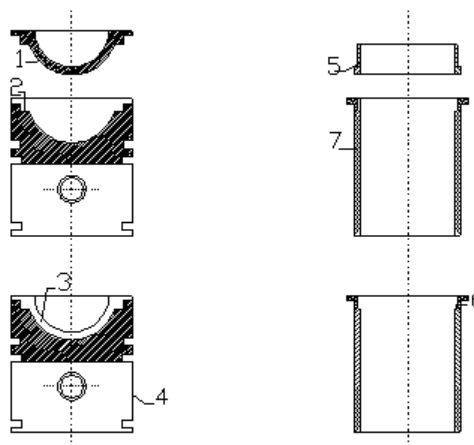

1 Superni crown with threads, 2 Superni gasket , 3.Air gap in piston, 4. Body of the piston, 5 Superni insert with threads , 6 Air gap in liner, 7. Body of the liner

**Fig.1** Assembly details of air gap insulated piston and air gap insulated liner

LHR-2 combustion chamber (Fig.1) contained a two-part piston; the top crown made of low thermal conductivity material, superni-90 (an alloy of nickel)

screwed to aluminum body of the piston, providing a 3 mm air gap in between the crown and the body of the piston. The optimum thickness of air gap in the air gap piston was found to be 3-mm for improved performance of the engine with diesel as fuel. [K. Ramamohan *et al*, 1999]. The height of the piston was maintained such that compression ratio was not altered.

A superni-90 insert was screwed to the top portion of the liner in such a manner that an air gap of 3-mm was maintained between the insert and the liner body. At 500°C the thermal conductivity of superni-90 and air are 20.92 and 0.057 W/m-K.

The test fuel used in the experimentation was neat diesel. The schematic diagram of the experimental setup with diesel operation is shown in Figure 2. The specifications of the experimental engine are shown in Table-2. Experimental setup used for study of exhaust emissions on low grade LHR diesel engine with cottonseed biodiesel in Fig.3 The specification of the experimental engine (Part No.1) is shown in Table.2 The engine was connected to an electric dynamometer (Part No.2. Kirloskar make) for measuring its brake power. Dynamometer was loaded by loading rheostat (Part No.3). The combustion chamber consisted of a direct injection type with no special arrangement for swirling motion of air. Burette (Part No.9) method was used for finding fuel consumption of the engine with the help of fuel tank (Part No7) and three way valve (Part No.8). Air-consumption of the engine was measured by air-box method consisting of an orifice meter (Part No.4), U-tube water manometer (Part No.5) and air box (Part No.6) assembly.

**Table.2** Specifications of the Test Engine

Description	Specification
Engine make and model	Kirloskar ( India) AV1
Maximum power output at a speed of 1500 rpm	3.68 kW
Number of cylinders × cylinder position × stroke	One × Vertical position × four-stroke
Bore × stroke	80 mm × 110 mm
Method of cooling	Water cooled
Rated speed ( constant)	1500 rpm
Fuel injection system	In-line and direct injection
Compression ratio	16:1
BMEP @ 1500 rpm	5.31 bar
Manufacturer's recommended injection timing and pressure	27°bTDC × 190 bar
Dynamometer	Electrical dynamometer
Number of holes of injector and size	Three × 0.25 mm
Type of combustion chamber	Direct injection type
Fuel injection nozzle	Make: MICO-BOSCH No- 0431-202-120/HB
Fuel injection pump	Make: BOSCH: NO-8085587/1

The naturally aspirated engine was provided with water-cooling system in which outlet temperature of water is maintained at 80°C by adjusting the water flow rate, which was measured by water flow meter (Part No.14). Exhaust gas temperature (EGT) and coolant water outlet temperatures were measured with thermocouples made of iron and iron-constantan attached to the exhaust gas temperature indicator (Part No.10) and outlet jacket temperature indicator (Part No.13). Copper shims of suitable size were provided in between the pump body and the engine frame, to vary the injection timing and its effect on the exhaust emissions and combustion characteristics of the engine was studied

Exhaust emissions of particulate matter and nitrogen oxides (NO<sub>x</sub>) were recorded by smoke opacity meter (AVL India, 437) and NO<sub>x</sub> Analyzer (Netel India ;4000 VM) at full load operation of the engine. Table 3 shows the measurement principle, accuracy and repeatability of raw exhaust gas emission analyzers/measuring equipment for particulate emissions and NO<sub>x</sub> levels. Analyzers were allowed to adjust their zero point before each measurement. To ensure that accuracy of measured values was high, the gas analyzers were calibrated before each measurement using reference gases.

Water cooled Piezo electric transducer(AVL Austria: QC34D), fitted on the cylinder head to measure pressure in the combustion chamber was connected to a console, which in turn was connected to Pentium personal computer.

TDC (top dead centre) encoder (AVL Austria: 365x) with a crank angle (CA) resolution of 0.5 crank angle degrees (CAD) provided at the extended shaft of the dynamometer was connected to the console to determine the crankshaft position.

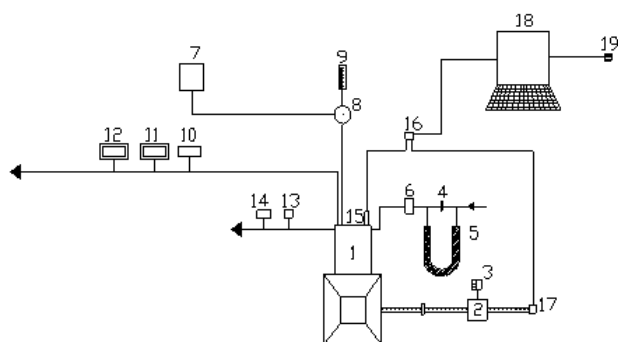

1.Engine, 2.Electical Dynamometer, 3.Load Box, 4.Orifice flow meter, 5.U-tube water manometer, 6.Air box, 7.Fuel tank, 8, Three way valve 9.Burette, 10. Exhaust gas temperature indicator, 11.Smoke opacity meter, 12.NO<sub>x</sub> Analyzer, 13.Outlet-jacket water temperature indicator, 14. Outlet-jacket water flow meter, 15. Piezo-electric pressure transducer, 16.Console, 17.TDC encoder, 18.Personal Computer and 19. Printer

**Fig.2** Schematic diagram of experimental set-up

The naturally aspirated engine was provided with water-cooling system in which outlet temperature of water is maintained at 80°C by adjusting the water flow rate. Engine oil was provided with a pressure feed system. No temperature control was incorporated, for measuring the lube oil temperature.

**Table.3** Specifications of the Smoke Opacimeter (AVL, India, 437) and NO<sub>x</sub> Analyzer (Netel India, (4000 VM))

Pollutant	Measuring Principle	Range	Least Count	Repeatability
Particulate Emissions	Light extinction	1-100%	0.1% of Full Scale (FS)	0.1% for 30 minutes
NO <sub>x</sub>	Chemiluminiscence	1-5000 ppm	0.5% of FS	≤0.5% F.S

A special pressure-crank angle (P-θ) software package evaluated the combustion characteristics such as peak pressure (PP), time of occurrence of peak pressure (TOPP) and maximum rate of pressure rise (MRPR) from the signals of pressure and crank angle at the peak load operation of the engine. Pressure-crank angle diagram was obtained on the screen of the personal computer.

*Operating Conditions*

Fuel used in experiment was neat diesel. Various injection timings attempted in the investigations were 27-34°bTDC.

**Results and Discussion**

*Performance Parameters*

The variation of brake thermal efficiency (BTE) with brake mean effective pressure (BMEP) in the conventional engine (CE) with pure diesel, at various injection timings at an injector opening pressure of 190 bar, is shown in Fig. 3.

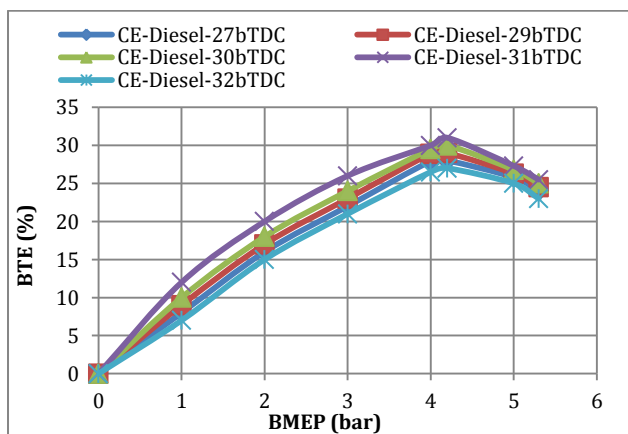
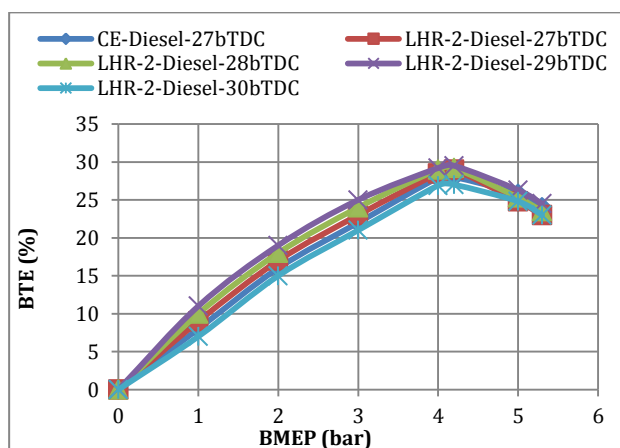

**Fig.3** variation of brake thermal efficiency (BTE) with brake mean effective pressure (BMEP) in the conventional engine with neat diesel, at various injection timings at an injector opening pressure of 190 bar

BTE increased with the advanced injection timings in the conventional engine at all loads, due to early initiation of combustion and increase of contact period of fuel with air leading to improve air fuel ratios period. The optimum injection timing was obtained by based on maximum brake thermal efficiency. Maximum BTE was observed when the injection timing was advanced to 31°bTDC in CE.

Performance deteriorated if the injection timing was greater than 31°bTDC. This was because of increase of ignition delay.

The variation of BTE with BMEP in the LHR-2 combustion chamber with neat diesel at various injection timings at an injector opening pressure of 190 bar, is shown in Fig. 4.



**Fig.3** variation of brake thermal efficiency (BTE) with brake mean effective pressure (BMEP) in the engine with LHR-2 combustion chamber with neat diesel, at various injection timings at an injector opening pressure of 190 bar

BTE increased up to 80% of the full load in the LHR-2 combustion chamber at the recommended injection timing and beyond this load, it decreased over and above that of the conventional engine. As the combustion chamber was insulated to greater extent, it was expected that high combustion temperatures would be prevalent in LHR engine. It tends to decrease the ignition delay thereby reducing pre-mixed combustion as a result of which, less time was available for proper mixing of air and fuel in the combustion chamber leading to incomplete combustion, with which BTE decreased beyond 80% of the full load. More over at this load, friction and increased diffusion combustion resulted from reduced ignition delay. Increased radiation losses might have also contributed to the deterioration. Higher value of BTE at all loads including 100% full load was observed when the injection timing was advanced to 29° bTDC in the LHR-2 combustion chamber. Further advancing of the injection timing resulted in increase in fuel consumption due to longer ignition delay. Hence it was concluded that the optimized performance of the LHR-2 combustion chamber was achieved at an injection timing of 29°bTDC.

### 3.2 Exhaust Emissions

Particulate emissions and nitrogen oxide (NO<sub>x</sub>) levels are the emissions from diesel engine cause health hazards like inhaling of these pollutants cause severe headache, tuberculosis, lung cancer, nausea, respiratory problems, skin cancer, hemorrhage, etc. [M.H. Fulekar, 1999; S.M.Khopkar, 2010; B.K.Sharma, 2010]. The contaminated air containing carbon dioxide released from automobiles reaches ocean in the form of acid rain, there by polluting water. Hence control of these emissions is an immediate task and important.

A rich fuel-air mixture resulted in higher smoke because of the availability of oxygen was less. Fig.4 indicates that particulate emissions increased from no load to full load in both versions of the combustion chamber. During the first part, the smoke level was more or less constant, as there was always excess air present. However, in the higher load range there was an abrupt rise in smoke levels due to less available oxygen, causing the decrease of air-fuel ratio, leading to incomplete combustion, producing more soot density.

The variation of smoke levels with the BMEP, typically showed a inverted L-shaped behavior due to the pre-dominance of hydrocarbons in their composition at light load and of carbon at high load. Up to 80% of full load, marginal reduction of particulate emissions was observed in the engine with LHR-2 combustion chamber, when compared to the conventional engine. This was due to the increased oxidation rate of soot in relation to soot formation. Higher surface temperatures of engine with LHR-2 combustion chamber aided this process. Soot formation and buildup in the engine cylinder was also a very important consideration. Soot is formed during combustion in low oxygen regions of the flames. Engine with LHR-2 combustion chamber shorten the delay period, which curbs thermal cracking, responsible for soot formation.

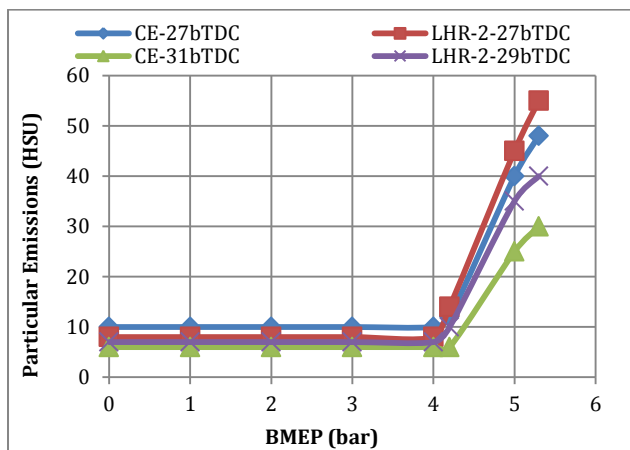

**Fig.4** Variation of particulate emissions in Hartridge Smoke Unit (HSU) with brake mean effective pressure (BMEP) in conventional engine (CE) and engine with LHR-2 combustion chamber at recommended injection timing and at optimized injection timing at an injector opening pressure of 190 bar

Beyond 80% of full load, marginal and slight increase of particulate emissions was observed in the LHR-2 combustion chamber, when compared to conventional engine. This was due to fuel cracking at higher temperature, leading to increase in smoke density. Higher temperature of LHR-2 combustion chamber produced increased rates of both soot formation and burn up. The reduction in volumetric efficiency and air-fuel ratio were responsible factors for increasing particulate emissions in the engine with LHR-2 combustion chamber near the full load operation of the engine. As expected, smoke increased in the LHR-2 combustion chamber because of higher temperatures and improper utilization of the fuel consequent upon predominant diffusion combustion. Particulate emissions decreased with advanced injection timing at all loads with engine with both versions of the combustion chamber. This was due to increase of contact period with fuel with air and thus improving atomization characteristics in both versions of the combustion chamber. Higher combustion temperatures are also conducive for reducing particulate emissions. Fuel cracking reactions were eliminated with LHR-2 combustion chamber due to low combustion temperatures. This confirmed improvement in fuel utilization with the injection timing of 29° bTDC. Rama Mohan also observed the similar trends.[Ramamohan et al, 1999]

Fig.5 indicates that engine with LHR-2 combustion chamber increased particulate emissions at full load by 25% at 27° bTDC and 33% at 29° bTDC in comparison with CE at 27° bTDC and 31° bTDC. This was due to reduction of ignition delay with engine with LHR-2 combustion chamber at 27° bTDC and increased injection timing advance with CE in comparison with insulated engine.

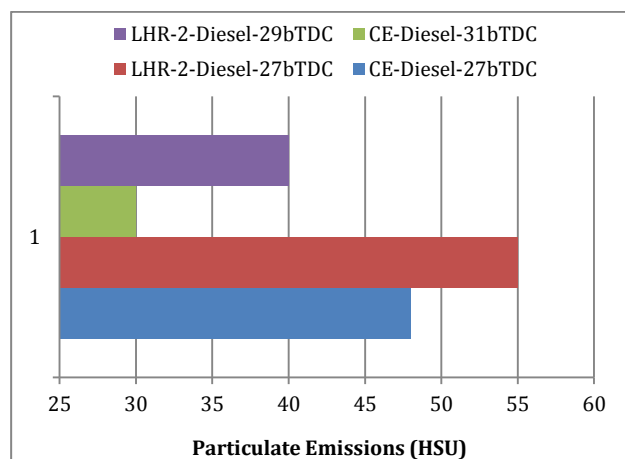

**Fig.5** Bar charts showing the variation of particulate emissions at full load with injection timing with both versions of the combustion chamber

Table.4 shows data of particulate emissions which varied with injector opening pressure with both versions of the engine.

**Table.4** Data of Particulate emissions

Injection Timing (bTDC)	Particulate Emissions (HSU)					
	Conventional Engine			LHR-2 Engine		
	Injector opening pressure (bar)			Injector opening pressure (bar)		
	190	230	270	190	230	270
27	48	40	34	55	50	45
29	---	---	---	40	35	30
31	30	35	40	---	---	---

Particulate emissions decreased marginally with an increase of injector opening pressure. Improved spray characteristics might have improved combustion which caused reduction of particulate emissions.

The temperature and availability of oxygen are the reasons for the formation of NO<sub>x</sub>. For both versions of the combustion chamber, Fig.6 indicates that NO<sub>x</sub> concentrations raised steadily as the fuel/air ratio increased with increasing BP/BMEP, at constant injection timing.

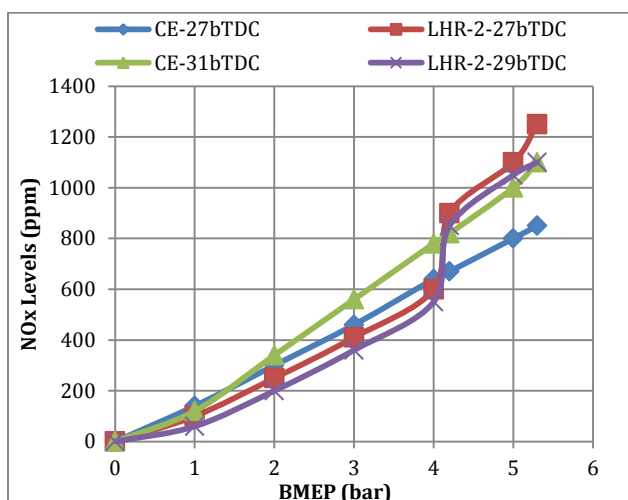

**Fig.6** Variation of nitrogen oxide (NO<sub>x</sub>) levels with brake mean effective pressure (BMEP) in conventional engine (CE) and engine with LHR-2 combustion chamber at recommended injection timing and at optimized injection timing at an injector opening pressure of 190 bar

At part load, NO<sub>x</sub> concentrations were less in both versions of the engine. This was due to the availability of excess oxygen. At remaining loads, NO<sub>x</sub> concentrations steadily increased with the load in both versions of the combustion chamber. This was because, local NO<sub>x</sub> concentrations raised from the residual gas value following the start of combustion, to a peak at the point where the local burned gas equivalence ratio changed from lean to rich. At full load, with higher peak pressures, and hence temperatures, and larger regions of close-to-stoichiometric burned gas, NO<sub>x</sub> levels increased in both versions of the engine. Though amount of fuel injected decreased proportionally as the overall equivalence ratio was decreased, much of the fuel still burns close to stoichiometric. Thus NO<sub>x</sub>

emissions should be roughly proportional to the mass of fuel injected (provided burned gas pressures and temperature do not change greatly).

The LHR-2 combustion chamber recorded lower NO<sub>x</sub> levels up to 80% of the full load, and beyond that load it produced higher NO<sub>x</sub> levels compared to conventional engine. As the air-fuel ratios were higher in the LHR-2 combustion chamber, causing more dilution, due to mixing with the excess air, leading to produce less NO<sub>x</sub> concentrations, up to 80% of the full load, when compared to CE. Beyond 80% of full load, due to the reduction of fuel-air equivalence ratio with LHR-2 combustion chamber, which was approaching to the stoichiometric ratio, causing higher value of NO<sub>x</sub> levels. NO<sub>x</sub> emissions increased with advanced injection timing with CE. Increasing the injection advance resulted in higher combustion temperatures and increase of resident time leading to produce higher value of NO<sub>x</sub> levels in the exhaust of conventional engine at its optimum injection timing. However, NO<sub>x</sub> levels decreased with advanced injection timing with engine with LHR-2 combustion chamber with diesel. This was due to decrease of combustion temperatures with improved air fuel ratios. Rama Mohan reported the similar trend with NO<sub>x</sub> emissions in the LHR engine at the recommended and optimum injection timings.[Ramamohan *et al*, 1999].

Fig.7 indicates that engine with LHR-2 combustion chamber increased NO<sub>x</sub> levels by 45% at 27° bTDC and comparable at 29° bTDC when compared with CE at 27° bTDC and at 31° bTDC. This was due to increase of peak pressures in the LHR-2 combustion chamber at 27° bTDC and resident time with CE.

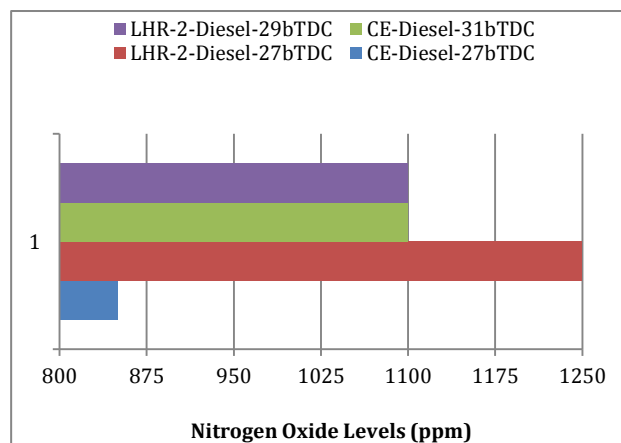

**Fig.7** Bar charts showing the variation of nitrogen oxide levels (NO<sub>x</sub>) at full load with injection timing with both versions of the combustion chamber

**Table.5** Data of Nitrogen oxide emissions

Injection Timing (bTDC)	Nitrogen oxide Emissions (ppm)					
	Conventional Engine			LHR-2 Engine		
	Injector opening pressure (bar)			Injector opening pressure (bar)		
	190	230	270	190	230	270
27	850	900	950	1250	1200	1150
29	--	---	---	1100	1050	1000
31	1100	1150	1200	---	---	---

Table.5 shows data of nitrogen oxide emissions which varied with injector opening pressure with both versions of the engine.

Nitrogen oxide levels increased marginally in conventional engine, while they decreased marginally with engine with LHR-2 combustion chamber with an increase of injector opening pressure with neat diesel operation. Enhanced spray characteristics, thus improving fuel air mixture preparation and evaporation process in conventional engine causing increase of nitrogen oxide levels in CE, while improved combustion with improved oxygen-fuel ratios in engine with LHR combustion chamber might have reduced nitrogen oxide levels in LHR-2 engine.

*Combustion Characteristics*

From Fig. 8, it is observed that peak pressure at full load operation increased with engine with LHR-2 combustion chamber at 27°bTDC in comparison with CE. This was due to high explosion of charge in hot environment provided by LHR combustion chamber.

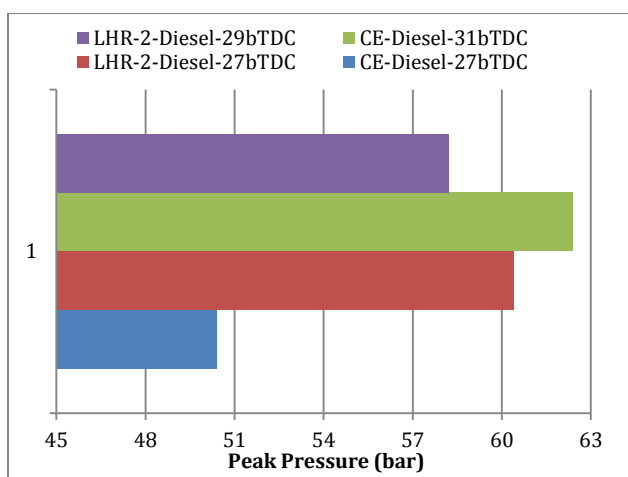
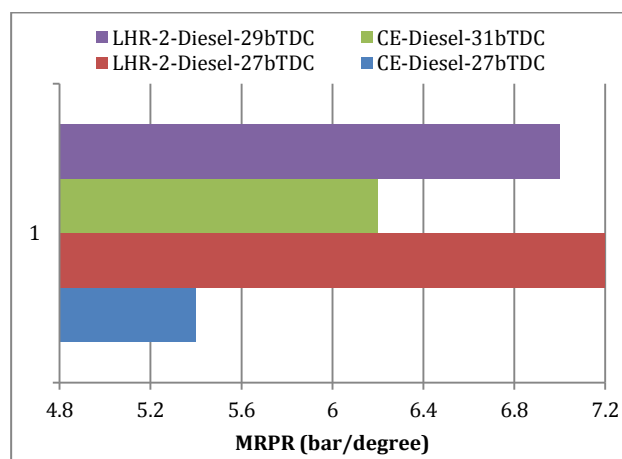

**Fig.8** Bar charts showing the variation of peak pressure at full load with injection timing with both versions of the combustion chamber

This was also because the LHR-2 combustion chamber exhibited higher temperatures of combustion chamber walls leading to continuation of combustion, giving rise higher peak pressures. PP increased with CE, while decreasing the same with engine with LHR-2 combustion chamber with advanced injection timings. This was due to explosion of accumulated charge with increase of ignition delay with CE, and improved combustion with improved air fuel ratios with which

gas temperatures and peak pressures decreased in LHR-2 version of the combustion chamber. Increase of NO<sub>x</sub> emissions with CE and decrease the same with engine with LHR-2 combustion chamber with advanced injection timings established the fact that PP at full load operation increased with CE, while decreasing the same with insulated engine with advanced injection timing. Engine with LHR-2 combustion chamber increased peak pressure at full load by 20% at 27° bTDC and 7% at 29° bTDC when compared with CE at 27° bTDC and at 31° bTDC.

Fig.9 indicates that Maximum rate of pressure raise (MRPR) at full load followed the similar trends with peak pressure in both versions of the combustion chamber. The trends observed by the authors on the aspect of MRPR in LHR-2 combustion chamber agreed well with the findings of Rama Mohan at the recommended injection timing. Engine with LHR-2 combustion chamber increased MRPR at full load by 33% at 27° bTDC and 13% at 29° bTDC when compared with CE at 27° bTDC and at 31° bTDC. This was due to reduction of ignition delay with insulated engine.



**Fig.9** Bar charts showing the variation of maximum rate of pressure rise (MRPR) at full load with injection timing with both versions of the combustion chamber

From Fig.10, it is observed that time of occurrence of peak pressure (TOPP) at full load decreased (shifted towards TDC) with the advanced injection timing and in both versions of the combustion chamber. This was confirmed that both versions of the combustion chamber showed improvement in performance, when the injection timings were advanced to their optimum values.

**Table.6** Data of combustion characteristics

Injection timing (bTDC)	Peak Pressure (bar)				MRPR (bar/deg)			
	CE		LHR-2		CE		LHR-2	
	Injector opening pressure (bar)		Injector opening pressure (bar)		Injector opening pressure (bar)		Injector opening pressure (bar)	
	190	270	190	270	190	270	190	270
27	50.4	53.5	60.4	56.7	5.4	6.0	7.2	6.4
29	---	---	58.2	54.4	---	---	7.0	6.2
31	62.4	60.6	---	---	6.2	5.6	---	---

Engine with LHR-2 combustion chamber increased TOPP at full load by 11% at 27° bTDC and 12% at 29° bTDC when compared with CE at 27° bTDC and at 31° bTDC. This was due to continuation of combustion with hot insulated components of LHR-2 combustion chamber giving TOPP away from TDC in comparison with CE.

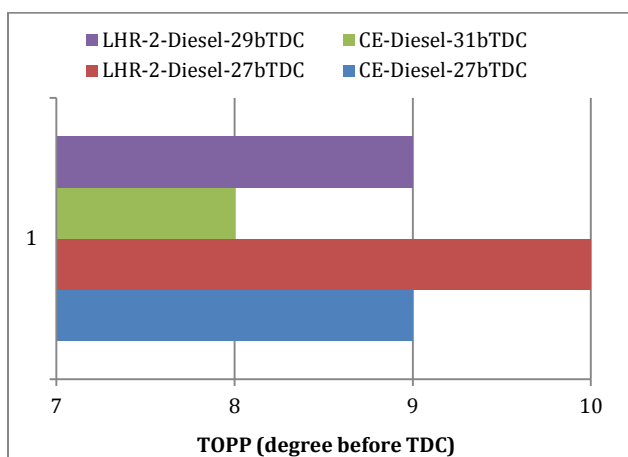

**Fig.10** Bar charts showing the variation of time of occurrence of peak pressure (TOPP) at full load with injection timing with both versions of the combustion chamber

Table.6 shows combustion characteristics varied with injector opening pressure. Peak pressures increased with the increase of injector opening pressure and with the advancing of the injection timing with diesel with conventional engine while they decreased in engine with LHR combustion chamber with advanced injection timing and an increased injector opening pressure as seen from Table.6. Peak pressure increased as injector opening increased. This may be due to smaller sauter mean diameter shorter breakup length, better dispersion, and better spray and atomization characteristics. This improves combustion rate in the premixed combustion phase in CE. Improved combustion with improved air fuel ratios might have reduced peak pressures marginally with LHR-2 engine with an increase of injector opening pressure. MRPR followed similar trends with peak pressure in both versions of the engine.

TOPP decreased marginally with an increase of injector opening pressure with both versions of the engine, which confirmed that combustion improved with an increase of injector opening pressure.

**Conclusions**

1. Engine with LHR-2 combustion chamber showed improved exhaust emissions of particulate emissions and NO<sub>x</sub> levels at 80% of the full load operation at 27 ° bTDC in comparison with conventional engine at 27 ° bTDC.
2. Engine with LHR-2 combustion chamber showed increased particulate emissions and NO<sub>x</sub> levels at the full load operation at 27 ° bTDC in comparison with conventional engine at 27 ° bTDC.
3. At full load operation, engine with LHR-2 combustion chamber at 29° bTDC, decreased particulate emissions by 27%, NO<sub>x</sub> levels by 12% , decreased peak pressure by 3%, MRPR by 3% and TOPP by 10% in comparison with same configuration of combustion chamber at an injection timing of 27 ° bTDC.
4. AT full load operation, conventional engine at 31° bTDC, decreased particulate emissions by 38%, NO<sub>x</sub> levels by 29%, peak pressure by 24%, MRPR by 15% and decreased TOPP by 11% in comparison with CE at an injection timing of 27 ° bTDC.
5. Increased injector opening pressure decreased particulate emissions and nitrogen oxide levels marginally in LHR-2 engine.

*Research Findings*

Comparative studies on exhaust emissions and combustion characteristic with direct injection diesel engine with LHR-2 combustion chamber and conventional combustion chamber were determined at varied injection timing with neat diesel operation.

*Future Scope of Work*

Hence further work on the effect of injector opening on pressure with engine with LHR-2 combustion chamber with diesel operation is necessary. Studies on performance parameters with varied injection timing and injection pressure with neat diesel operation on engine with LHR-2 combustion chamber can be taken up.

**Acknowledgments**

Authors thank authorities of Chaitanya Bharathi Institute of Technology, Hyderabad for providing

facilities for carrying out this research work. Financial assistance provided by All India Council for Technical Education (AICTE), New Delhi, is greatly acknowledged.

## References

- Matthias Lamping, Thomas Körfer, Thorsten Schnorbus, Stefan Pischinger, Yunji Chen. (2008), Tomorrows Diesel Fuel Diversity – Challenges and Solutions, SAE 2008-01—1731
- Cummins, C. and Jr. Lyle. (1993), Diesel's Engine, Volume 1: From Conception To 1918. Wilsonville, OR, USA: Carnot Press, ISBN 978-0-917308-03-1, 1993.
- Avinash Kumar Agarwal, Dhananjay Kumar Srivastava, Atul Dhar, Rakesh Kumar Maurya, Pravesh Chandra Shukla, Akhilendra Pratap Singh. (2013), Effect of fuel injection timing and pressure on combustion, emissions and performance characteristics of a single cylinder diesel engine, *Fuel*, 111 pp 374–383.
- Wallace, F.J., Kao, T.K., Alexander, W.D., Cole, A. and Tarabad, M. (1983), Thermal barrier piston and their effect on the performance of compound diesel engine cycles, SAE Paper No. 830312, 1983.
- Karthikeyan, S., Arunachalam, M., Srinivasan Rao, P. and Gopala Krishnan, K.V. (1985), Performance of an alcohol, diesel oil dual-fuel engine with insulated engine parts”, Proceedings of 9th National Conference of I.C. Engines and Combustion, pp 19-22, Indian Institute of Petroleum, Dehradun.
- Jabez Dhinagar, S., Nagalingam, B. and Gopala Krishnan, K.V. (1989), Use of alcohol as the sole fuel in an adiabatic diesel engine, Proceedings of XI National Conference on IC Engines and Combustion, pp: 277-289, I.I.T., Madras, 1989.
- Parker, D.A. and Dennison, G.M. (1987), The development of an air gap insulated piston”. SAE Paper No. 870652, 1987.
- Rama Mohan, K., Vara Prasad, C.M. and Murali Krishna, M.V.S. (1999), Performance of a low heat rejection diesel engine with air gap insulated piston, *ASME Journal of Engineering for Gas Turbines and Power*, 121(3), pp 530–540.
- Vara Prasad, C.M, Murali Krishna, M.V.S., Prabhakar Reddy, C. and Rama Mohan, K. (2000). Performance evaluation of non edible vegetable oils as substitute fuels in low heat rejection diesel engine. *Institute of Engineers (London)*, 214(2), Part-D, *Journal of Automobile Engineering*, pp 181-187.
- Murali Krishna, M.V.S. (2004). Performance evaluation of low heat rejection diesel engine with alternate fuels. PhD Thesis, J. N. T. University, Hyderabad.
- Chennakesava Reddy, Murali Krishna, M.V.S., Murthy, P.V.K., and Ratna Reddy, T. (2011). Potential of low heat rejection diesel engine with crude pongamia oil. *International Journal of Modern Engineering Research*, 1(1), pp 210-224.
- Janardhan, N., Murali Krishna, M.V.S., Ushasri, P. and Murthy, P.V.K. (2012). Potential of a medium low heat rejection diesel engine with crude jatropha oil. *International Journal of Automotive Engineering and Technologies*, 1(2), pp 1-16
- Murali Krishna, M.V.S., Durga Prasada Rao, N., Anjeneya Prasad, A. and Murthy, P.V.K. (2013). Improving of emissions and performance of rice brawn oil in medium grade low heat rejection diesel engine. *International Journal of Renewable Energy Research*, 3(1), pp 98-108.
- Srikanth, D., Murali Krishna, M.V.S., Ushasri, P. and Krishna Murthy, P.V. (2013), Comparative studies on medium grade low heat rejection diesel engine and conventional diesel engine with crude cotton seed oil, *International Journal of Innovative Research in Science, Engineering and Technology*, 2(10), pp 5809-5228.
- Janardhan, N., Murali Krishna, M.V.S. and Ushasri, P. (2014), Influence of injector opening pressure on performance and exhaust emissions in DI diesel engine with air gap insulated piston and air gap insulated liner with diesel operation, *International Journal for Advance Research in Engineering and Technology*, 2(4), pp 107–115.
- Janardhan, N., Murali Krishna, M.V.S., Kesava Reddy, Ch. and Durga Prasada Rao. D. (2015), Effect of injection timing on performance parameters of DI diesel engine with air gap insulation, *International Journal of Thermal Technologies, March*, 5(1), pp 9–17.
- Janardhan, N., Murali Krishna, M.V.S. and Usha Sri, P. (2015), Studies on influence of injection pressure on performance parameters of diesel engine with medium grade low heat rejection combustion chamber, *International Journal of Application or Innovation in Engineering and Management*, June, 4(5), pp 362-375.
- Janardhan, N., Murali Krishna, M.V.S. and Usha Sri, P. (2015), Influence of injection timing on exhaust emissions and combustion characteristics of low heat rejection diesel engine with air gap insulation, *International Journal of Current Engineering and Technology*, October, 5(5), 3364-3371
- Fulekar, M. H. (1999), Chemical pollution – a threat to human life, *Indian Journal of Environmental Technology*, 1, pp 353-359.
- Khopkar, S.M. (2010), Environmental Pollution Analysis, [New Age International (P) Ltd, Publishers, New Delhi], pp 180-190.
- Sharma, B.K. (2010), Engineering Chemistry, [Pragathi Prakashan (P) Ltd, Meerut], pp 150-160.