

Research Article

Algorithm for optimized PID Controller design using Performance index parameter

Chaman Yadav^{†*} and Mahesh Singh[†]

[†]EE, SSTC Bhilai, Chhatisgarh India

Accepted 02 June 2015, Available online 12 June 2015, Vol.5, No.3 (June 2015)

Abstract

Controllers are widely used in power industrial field to control system because wide range of the tuned parameter. There are several methods which are used to tune the controller parameters. They are categorized into two types known as classical methods and modern methods. This paper presents the design of controller to tuned by the one of the modern algorithm techniques i.e. Particle Swarm Optimization (PSO). In this paper the use of PSO method tuned the PID parameter to make them more general and to achieve the steady state error limit, also to improve the dynamic behavior of the system. The performance and design criteria of automatic selection of controller constants are discussed below.

Keywords: PSO Particle Swarm Optimization BFO Bacterial Foraging Optimization PID Proportional Integral Derivative

1. Introduction

PID controller consists of Proportional, Integral and Derivative gains. The PID feedback control system is illustrated in Fig. 1 where r, e, y are respectively the reference, error and controlled variables. Where K_p is proportional gain, K_i is integral gain and K_d is derivative gain.

In the diagram of Fig.1, G(s) is the plant transfer function and C(s) is the PID controller transfer function that is given as:

$$C(s) = K_p + \frac{K_i}{s} + K_d$$

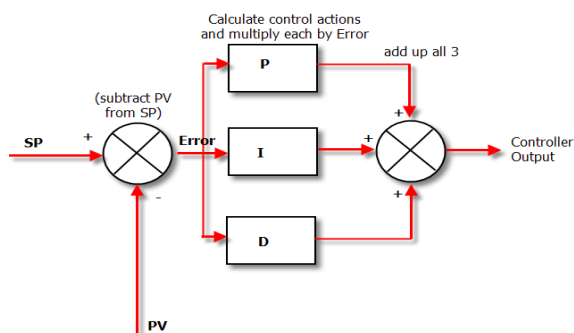

Where K_p, K_i, K_d parameters of the PID controllers that are going to be tuned using BF-PSO.

2. Performance Indices

Quantification of system performance is achieved through a performance index. The performance selected depends on the process under consideration and is chosen such that emphasis is placed on specific aspects of system performance. Furthermore, performance index is defined as a quantitative measure to depict the system performance of the designed PID controller. Using this technique an 'optimum system' can often be designed and a set of PID parameters in the system can be adjusted to meet the required specification. For a PID- controlled system, there are often four indices to depict the system performance **ISE, IAE, and IATE**. They are defined as follows:

Integral square error defined as the error of an output, squared and added (integrated) over continuous time is used to measure system performance in applications of optimal control and estimation.

$$ISE = \int_0^{\infty} e^2(t)dt$$

Another index is the Integral of the Absolute magnitude of Error (IAE) which is the mode of the error for providing better stability to the system which can be written as

$$IAE = \int_0^T |e(t)|dt$$

*Corresponding author: Chaman Yadav

The third one is the ITAE which is used to minimize the large errors in the system defined as the integration of the absolute of error with respect to time. Mathematical expression of ITAE is given by

$$ITAE = \int_0^T t|e(t)| dt$$

The last one is the ITSE it is also minimized the large error. It is defined as the integral of the absolute square error or to integrate the large error to minimize the unstable condition.

3. Overview of PSO Algorithm

PSO is optimization algorithm based on evolutionary computation technique. The basic PSO is developed from research on swarm such as fish schooling and bird flocking. After it was firstly introduced in 1995, a modified PSO was then introduced in 1998 to improve the performance of the original PSO. A new parameter called inertia weight is added. This is a commonly used PSO where inertia weight is linearly decreasing during iteration in addition to another common type of PSO which is reported by Clerk.

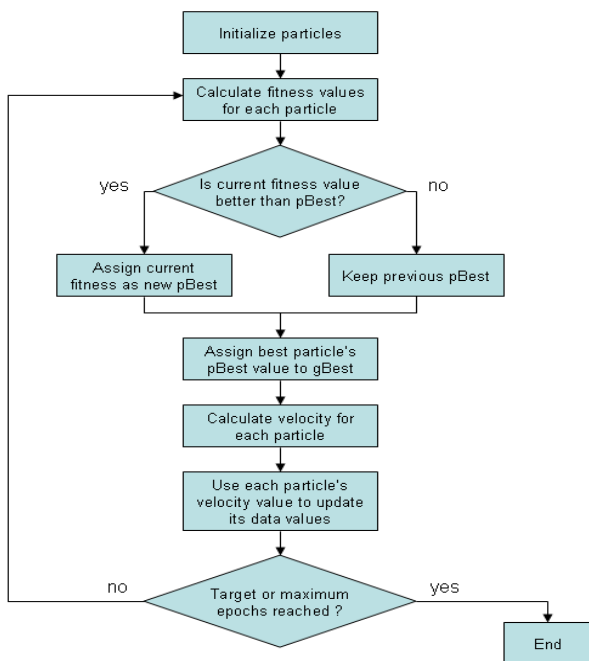

The later is the one used in this paper. In PSO, instead of using genetic operators, individuals called as particles are evolved by cooperation and competition among themselves through generations. A particle represents a potential solution to a problem. Each particle adjusts its flying according to its own flying experience and its companion flying experience. Each particle is treated as a point in a D-dimensional space. The *i*th particle is represented as $X_i=(x_{i1},x_{i2},...,x_{iD})$. The best previous position (giving the minimum fitness value) of any particle is recorded and represented as $PI=(p_{i1},p_{i2},...,p_{iD})$, this is called *pbest*. The index of the

best particle among all particles in the population is represented by the symbol *g*, called as *gbest*. The velocity for the particle *i* is represented as $V_i=(v_{i1},v_{i2},...,v_{iD})$. The particles are updated according to the parameters of the PSO.

$$V_{j(i)} = v_{j,1(i)}; v_{j,2(i)}; \dots v_{j,k(i)}; \dots; v_{j,d(i)}$$

4. Bacterial Foraging Optimization

Introduction Based on the research of foraging behaviour of E.colli bacteria Kevin M.Passino and Liu exploited a variety of bacterial foraging and swarming behaviour, discussing how to connect social foraging process with distributed non-gradient optimization. In the bacterial foraging optimization process four motile behaviours are mimicked:-

1) Chemotaxis

A chemotactic step can be defined as a tumble followed by a tumble or a tumble followed by a run lifetime.To represent a tumble a unit length random direction, (*j*), is generated ; this will be used to define the direction of movement after a tumble. In particular

$$i(j+1,k,l) = i(j,k,l) + C(i)* (j)$$

Where $i(j,k,l)$ represents the *i*th bacterium at *j*th chemotactic, *k*th reproductive and *l*th elimination and dispersal step.*C*(*i*) is the size of the step taken in the random direction specified by a tumble(run length unit).

2) Swarming

E.Colli cell scan cooperatively self organize into highly structured colonies with elevated environmental adaptability using an intricate communication mechanism. Overall, cells

3) Reproduction

The least healthier bacteria die and the other each healthier bacteria split into two new bacteria each placed in the same location.

4) Elimination and Dispersal

It is possible that in the local environment, the lives of a population of bacteria changes either gradually (eg, via consumption of nutrients) or suddenly due to some other influence. Events can occur that all the bacteria in a region are killed or a group is dispersed into a new part of the environment. They have the effect of possibly destroying the chemotactic progress, but they have also the effect of assisting the chemotactic process, since dispersal may place bacteria near good food sources. From a board perspective, elimination and disposal are parts of the population level long distance motile behaviour.

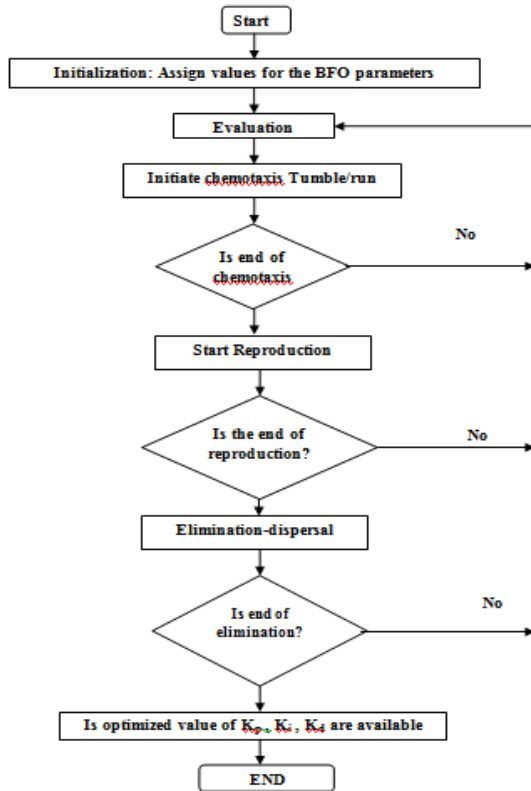

| S no. | n | α | β | Kp | Kd | Mp% | Ts | Tr |
|-------|----|----------|---------|------|------|-------|------|-------|
| 1 | 50 | 10 | 10 | 0.96 | 0.85 | 22.53 | 9.27 | 1.482 |
| 2 | 50 | 10 | 10 | 0.88 | 0.67 | 8.17 | 8.31 | 1.699 |

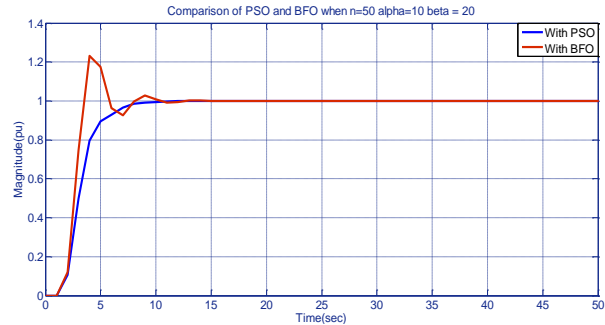

When n=50 (i.e. number of iteration denoted by generation) in this case considering the value of Alpha to be 10 and Beta to be 10. From the figure it is also clear that the maximum overshoot and settling time of BFO is greater than that of PSO, and the rise time is smaller than that of PSO.

| S no. | n | α | β | Kp | Kd | Mp% | Ts | Tr |
|-------|----|----------|---------|------|------|-------|-------|-------|
| 1 | 50 | 10 | 10 | 0.74 | 0.66 | 0.663 | 7.038 | 2.054 |
| 2 | 50 | 10 | 10 | 0.84 | 0.77 | 2.343 | 8.118 | 1.822 |

5. Simulation and results

Functions are used for designing PID controller ISE, IAE, ITAE and ITSE .We set the following parameters

- Dimension of search space =3;
- The number of bacteria =10;
- Number of chemotactic steps =10;
- Limits the length of a swim =4;
- The number of reproduction steps =4;

- The number of elimination-dispersal events =2;
- The number of bacteria reproductions (splits) per generation =s/2;
- The probability that each bacteria will be eliminated/dispersed =0.25;
- $c(:,1)=0.5*\text{ones}(s,1)$; the run length.

We use the following PSO parameters
 C1=1.2;
 C2= 0.5;
 W=0.9;

| S no. | n | α | β | Kp | Kd | Mp% | Ts | Tr |
|-------|----|----------|---------|------|-------|-------|-------|-------|
| 1 | 50 | 10 | 5 | 0.96 | 0.854 | 22.53 | 9.275 | 1.484 |
| 2 | 50 | 10 | 5 | 0.88 | 0.672 | 8.178 | 8.317 | 1.699 |

The response in Figure shows that the comparison of PSO and BFO when the number of iteration is 50 and alpha =10 and beta =20 in such a condition the output response of the system gives the value of maximum overshoot, rise time, settling time, and also the value of the gain i.e. the proportional gain and the integral gain.

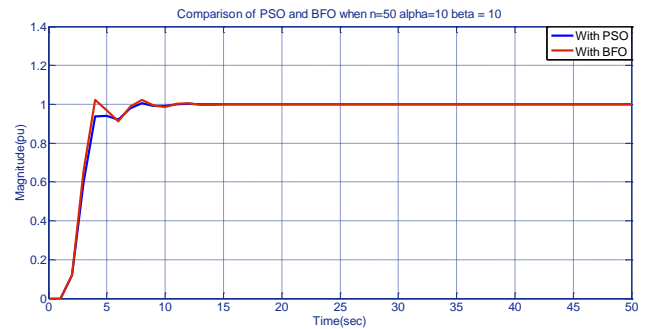

When n=50 (i.e. number of iteration denoted by generation) in this case considering the value of Alpha to be 10 and Beta to be 10. From the figure it is also clear that the maximum overshoot and settling time of BFO is greater than that of PSO, and the rise time is smaller than that of PSO.

| S no. | n | α | β | Kp | Kd | Mp% | Ts | Tr |
|-------|----|----------|---------|------|------|-------|-------|-------|
| 1 | 50 | 10 | 15 | 0.81 | 0.83 | 0.945 | 6.894 | 1.887 |
| 2 | 50 | 10 | 15 | 0.87 | 0.80 | 0.727 | 8.313 | 1.743 |

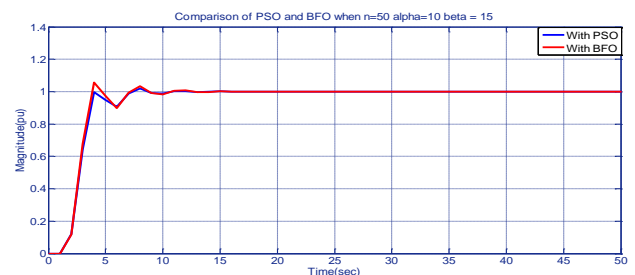

When n=50 (i.e. number of iteration denoted by generation) in this case considering the value of Alpha to be 10 and Beta to be 10. From the figure it is also clear that the maximum overshoot and settling time of

BFO is greater than that of PSO, and the rise time is smaller than that of PSO.

| S no. | n | α | β | Kp | Kd | Mp% | Ts | Tr |
|-------|----|----------|---------|------|-----|------|------|-------|
| 1 | 50 | 10 | 20 | 0.56 | 0.5 | 0.81 | 0 | 7.718 |
| 2 | 50 | 10 | 20 | 0.97 | 0.9 | 0.40 | 23.0 | 9.354 |

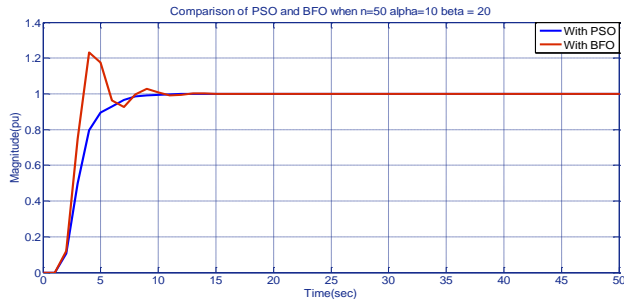

When n=50 (i.e. number of iteration denoted by generation) in this case considering the value of Alpha to be 10 and Beta to be 20. From the figure it is also clear that the maximum overshoot and settling time of BFO is greater than that of PSO, and the rise time is smaller than that of PSO.

| S no. | n | α | β | Kp | Kd | Mp% | Ts | Tr |
|-------|-----|----------|---------|------|-----|-------|-------|-------|
| 1 | 200 | 10 | 5 | 0.72 | 0.8 | 0.855 | 0.276 | 7.128 |
| 2 | 200 | 10 | 5 | 0.69 | 0.6 | 0.552 | 0 | 21.74 |

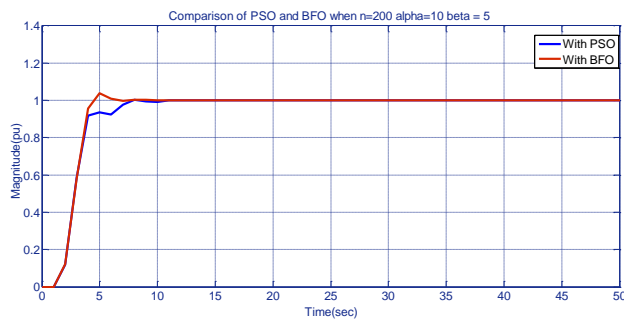

When n=50 (i.e. number of iteration denoted by generation) in this case considering the value of Alpha to be 10 and Beta to be 10. From the figure it is also clear that the maximum overshoot and settling time of BFO is greater than that of PSO, and the rise time is smaller than that of PSO.

| S no. | n | α | β | Kp | Kd | Mp% | Ts | Tr |
|-------|-----|----------|---------|------|------|------|------|-------|
| 1 | 200 | 10 | 10 | 0.73 | 0.75 | 0.86 | 0.47 | 7.084 |
| 2 | 200 | 10 | 10 | 0.81 | 0.89 | 0.47 | 10.4 | 7.019 |

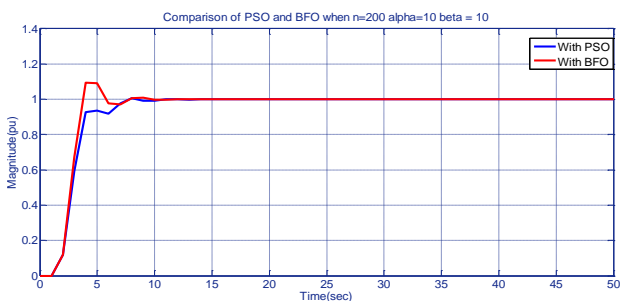

When n=200 (i.e. number of iteration denoted by generation) in this case considering the value of Alpha to be 10 and Beta to be 10. From the figure it is also clear that the maximum overshoot and settling time of BFO is greater than that of PSO, and the rise time is smaller than that of PSO.

| S no. | n | α | β | Kp | Kd | Mp% | Ts | Tr |
|-------|-----|----------|---------|------|------|------|------|-------|
| 1 | 200 | 10 | 15 | 0.84 | 0.68 | 0.78 | 2.42 | 8.135 |
| 2 | 200 | 10 | 15 | 0.54 | 0.74 | 0.34 | 4.97 | 8.195 |

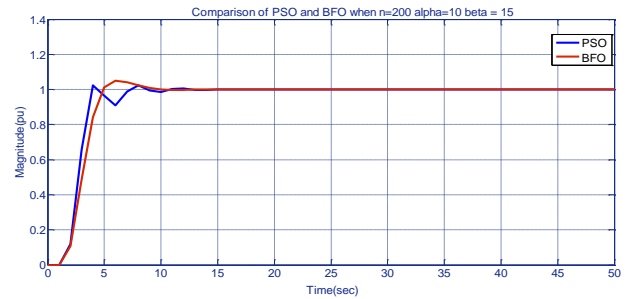

| S no. | n | α | β | Kp | Kd | Mp% | Ts | Tr |
|-------|-----|----------|---------|------|-----|-----|-------|-------|
| 1 | 200 | 10 | 20 | 0.72 | 0.6 | 0.8 | 0.276 | 7.128 |
| 2 | 200 | 10 | 5 | 0.69 | 0.7 | 0.5 | 0 | 21.74 |

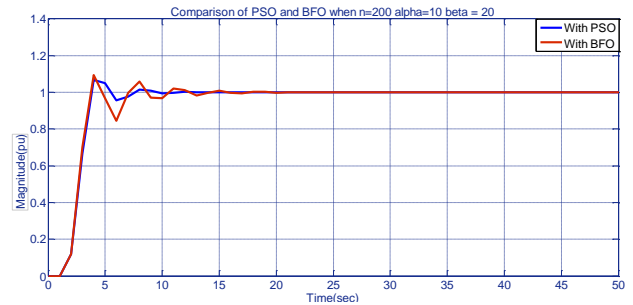

When n=200 (i.e. number of iteration denoted by generation) in this case considering the value of Alpha to be 10 and Beta to be 20. From the figure it is also clear that the maximum overshoot and settling time of BFO is greater than that of PSO, and the rise time is smaller than that of PSO.

| S no. | n | α | B | Kp | Kd | Mp% | Ts | Tr |
|-------|-----|----------|----|------|-----|------|------|-------|
| 1 | 200 | 10 | 10 | 0.72 | 0.8 | 0.65 | 0.27 | 7.128 |
| 2 | 200 | 10 | 10 | 0.69 | 0.5 | 0.55 | 0.35 | 21.74 |

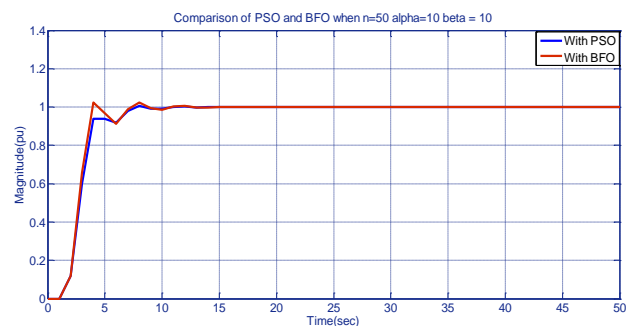

When $n=50$ (i.e. number of iteration denoted by generation) in this case considering the value of Alpha to be 10 and Beta to be 10. From the figure it is also clear that the maximum overshoot and settling time of BFO is greater than that of PSO, and the rise time is smaller than that of PSO.

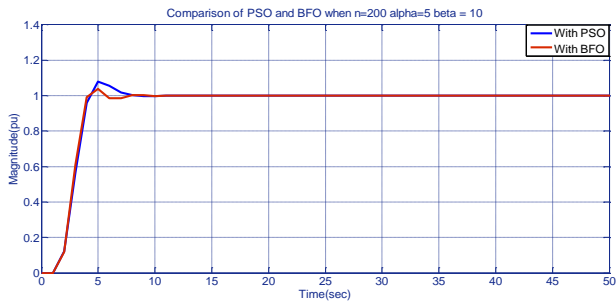

| S no. | n | α | β | Kp | Kd | Mp% | Ts | Tr |
|-------|-----|----------|---------|------|------|-------|------|-------|
| 1 | 200 | 10 | 5 | 0.72 | 0.89 | 0.685 | 0.68 | 7.128 |
| 2 | 200 | 10 | 5 | 0.69 | 0.56 | 0.921 | 0.58 | 21.74 |

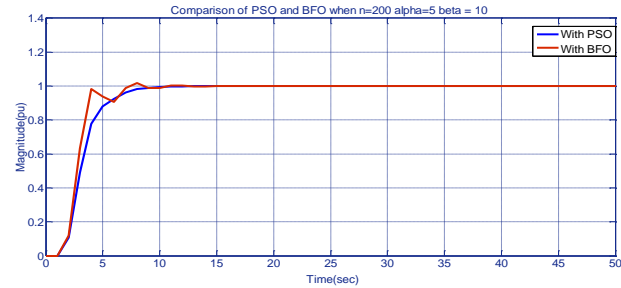

When $n=200$ (i.e. number of iteration denoted by generation) in this case considering the value of Alpha to be 5 and Beta to be 10. From the figure it is also clear that the maximum overshoot and settling time of BFO is greater than that of PSO, and the rise time is smaller than that of PSO

| S no. | n | α | β | Kp | Kd | Mp% | Ts | Tr |
|-------|-----|----------|---------|------|------|-------|------|-------|
| 1 | 200 | 15 | 10 | 0.72 | 0.96 | 0.985 | 0.62 | 5.128 |
| 2 | 200 | 15 | 10 | 0.69 | 0.52 | 0.732 | 0.32 | 21.74 |

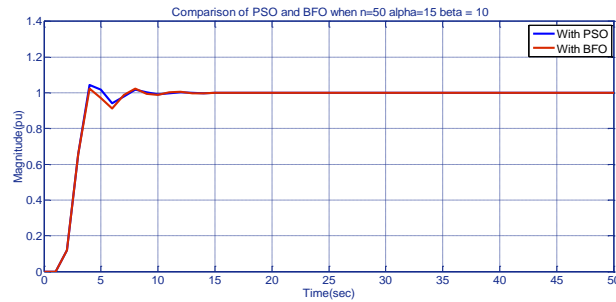

| S no. | n | α | β | Kp | Kd | Mp% | Ts | Tr |
|-------|-----|----------|---------|------|-------|-------|------|------|
| 1 | 200 | 10 | 5 | 0.72 | 0.6 | 0.728 | 0.2 | 7.12 |
| 2 | 200 | 10 | 5 | 0.69 | 0.508 | 0.896 | 0.35 | 21.7 |

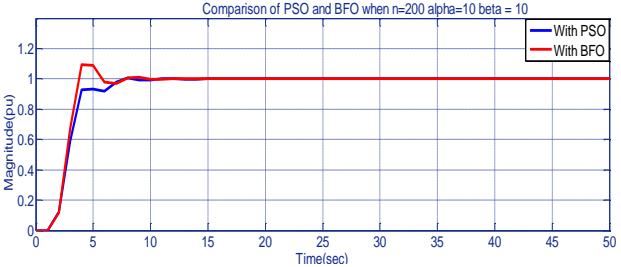

When $n=200$ (i.e. number of iteration denoted by generation) in this case considering the value of Alpha to be 10 and Beta to be 20. From the figure it is also clear that the maximum overshoot and settling time of BFO is greater than that of PSO, and the rise time is smaller than that of PSO

| S no. | n | α | β | Kp | Kd | Mp% | Ts | Tr |
|-------|-----|----------|---------|------|------|-------|------|------|
| 1 | 200 | 20 | 10 | 0.72 | 0.7 | 0.855 | 0.27 | 7.12 |
| 2 | 200 | 20 | 10 | 0.69 | 0.68 | 0.552 | 0.63 | 21.7 |

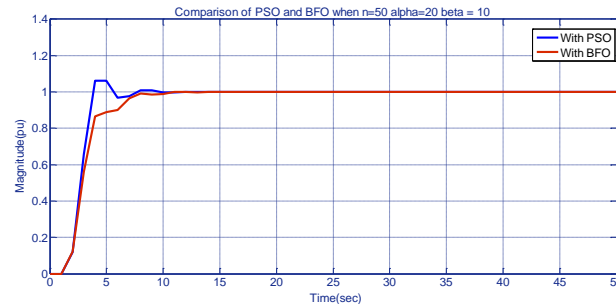

When $n=200$ (i.e. number of iteration denoted by generation) in this case considering the value of Alpha to be 10 and Beta to be 10. From the figure it is also clear that the maximum overshoot and settling time of BFO is greater than that of PSO, and the rise time is smaller than that of PSO

| S no. | n | α | β | Kp | Kd | Mp% | Ts | Tr |
|-------|-----|----------|---------|------|------|-------|-------|-------|
| 1 | 200 | 10 | 5 | 0.72 | 0.64 | 0.855 | 0.276 | 7.128 |
| 2 | 200 | 10 | 5 | 0.69 | 0.78 | 0.552 | 0 | 21.74 |

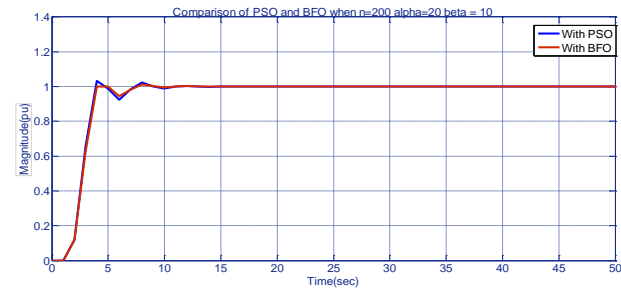

When $n=50$ (i.e. number of iteration denoted by generation) in this case considering the value of Alpha to be 20 and Beta to be 10. From the figure it is also clear that the maximum overshoot and settling time of BFO is greater than that of PSO, and the rise time is smaller than that of PSO

When $n=200$ (i.e. number of iteration denoted by generation) in this case considering the value of Alpha to be 10 and Beta to be 5. From the figure it is also

clear that the maximum overshoot and settling time of BFO is greater than that of PSO, and the rise time is smaller than that of PSO.

Conclusion

In this thesis, various classical as well as modern methods of PID tuning is discussed according to that they are implemented for the stability enhancement of the plant. The results are observed are discussed in the result and simulation part. Next PID tuning is achieved by two of the modern techniques namely Particle Swarm Optimization (PSO) algorithm and Bacterial Foraging Optimization (BFO) algorithm for the stability enhancement of the plant.

The result for the plant model system is achieved by manipulating the values of the gain parameters of the PID controller namely proportional gain, integral gain, and derivative gain. Also there is a compromise in overshoot rise time and settling time while making a choice between two categories of PID tuning. From the closed discussion it is seen that by applying PSO algorithm it provides optimal values for PID parameters for better system performance. Using PSO it can be seen that the best overshoot is achieved many times along with good rise time as well as settling time.

BFO algorithm is next optimization technique applied for optimization of PID parameters for stability enhancement of plant model. Overshoot, rise time and settling time are achieved in specified range but as compare to PSO it is not.

References

- Dingyu Xuet and D.P. Atherton (Dec 1993) ,A reduction based pid controller design algorithm for a class of plant model,u.k. proceeding of 23 conference on decision and control.
- Anitha Mary.x and l.sivakumar (May 2012) a reduced order transfer function models for alstom gasifier using genetic algorithm international journal of computer applications (0975 – 8887) volume 46– no.5.
- Yogendra Kumar Soni and Rajesh Bhatt (March-2013) PSO optimized reduced order PID Controller designInternational Journal Of Advanced Resarch in Computer Engineering & Technology, Volume 2 Issue 3 ,pp 989-992
- S. Morkos and H. Kamal (March 2012) Optimal Tuning of PID Controller using Bacteria Foraging based Particle Swarm Optimization Algorithm, Int. J. of Computers, Communications & Control, Vol. VII, No. 1, pp. 101-114
- Vinay Gupta, AshisPatra (2011)Design of Self-Tune PID Controller for Governor Control to Improve Dynamic Characteristics –International Conference (ICITM-2011) to be held on 3rdJuly2011 at Ranchi, India
- S.R.Vaishnav, Z.J.Khan (2007)Design and Performance of PID and Fuzzy Logic Controllers with Smaller Rule Set for Higher Order System, International Conference on Control & Automation (ICCA'07), HongKong, china, pp.1469-1472.
- J.G. Ziegler and N.B.Nichols (1942) Optimal Setting for Automatic Controller, Trans. ASME, Vol.64, pp.759-768.
- M. Zhuang and D.P. Athertong (1993)Automatic Tuning of Optimum PID Controller, IEE proceeding part-D: control Theory and ApplicationVol.140, No.3, pp.216-224.
- K.J. Astrom and T. Haglund (1995)PID Controller: Theory, Design and Tuning, 2nded.Research Tringle park, NC: Instrum.Soc.Amer.
- K.H. Ang, G. Chong and Y. Li (2005)PID Control System Analysis, Design and Technology, IEEE Transaction on Control System Technology, Vol.13, No.4, pp.559-576.