

Research Article

Design of Controller for Chopper Fed DC Drive with Pulsating Load and Elastic Coupling under Resonance

Pradeep Kumar^A, Upendra K. Agarwal^B and Vijay Kumar Sharma^{A*}^ADepartment of Physics, Shyam Lal College (University of Delhi), Shahdara, Delhi, India^BDepartment of Electrical Engineering, R. D. Engineering College, Ghaziabad, U. P., India

Accepted 12 July 2014, Available online 01 Aug 2014, Vol.4, No.4 (Aug 2014)

Abstract

The performance of an electric drive not only depends on its electrical parts, but is significantly affected by its mechanical features. These mechanical features include elasticity of shaft, misalignment, backlash etc. These mechanical factors may cause resonance in the system and the armature current and torque may rise to very high magnitude. This resonance condition may cause damage to the entire drive system. The development of high performance d. c. drive system requires a more precise analysis of resonance condition of such system. This paper is mainly focused to analyze the performance of drive under normal running and resonance condition for the dc drive system, to design a suitable controller to protect the system under resonance condition and analyze the performance of drive with suitable controller designed.

Keywords: DC Drive, resonance, pulsating load and supply, intermittent load and supply, controller, elasticity, shear stress.

Introduction

The mechanical factors like elasticity of shaft, backlash, misalignment, bending of shaft and unbalance of rolls, affect the performance of electric drive severely. The study of these mechanical factors has attracted the attention of researchers in the past. A comprehensive description of various mechanical factors affecting the performance of electric drives is already given [W.C. Carter et al, 1969, G.W. Buckley et al, 1980 and V. Atarod et al 1992]. The effect of these factors is mainly to produce torsional oscillations in the system, and to impose cyclic rotational disturbances in the form of either impact loads or periodic change in load torques. The system instability at resonance is discussed and possible methods of stabilization are suggested. The need of accurate modeling of total system including the system non-linearities and component interactions have been suggested [J.A. Bishop et al, 1979]. The drive system has been divided into four functional system components. Drive system disturbance sources such as pulsating torques, imbalances and switching transients of the drive motor, impact and cyclic effects of load and mechanical inaccuracies, the various sources of excitation of torsional oscillations for cement industry drives [C.B. Mayer et al 1981] are also discussed. The importance of torsional mechanical system with electric drive and its control has been emphasized. The analysis of d.c. drives with pulsating load torque and elastic mechanical link between

motor and the load has been carried out. A mathematical model of the system using state space technique is given [D.R. Kohli et al 1981, 1980] and the equations are solved to obtain the closed form solution for motor speed and current under transient and steady state conditions.

System description of DC drive

The system shown in fig 1 shows a separately excited DC motor coupled to the load through an elastic shaft. The motor-load system can be represented by two rotor system. The moments of inertia J_1 , J_2 and damping B_1 , B_2 of motor and load respectively, are considered separately as shown in above figure. The shaft is considered to be elastic in nature having elasticity of shaft C . the motor torque T_e is considered to be positive whereas the load torque T_L is considered to be negative. The angular positions at motor and load ends are θ_1 and θ_2 . For a Perfectly rigid shaft, values of θ_1 and θ_2 are same. But for elastic shaft, θ_1 and θ_2 are different and this gives rise to twist $(\theta_1 - \theta_2)$ in the shaft is running condition. The input to the motor is through a chopper with a freewheeling diode in parallel with armature to allow the flow of current during the pulse off periods [S. U. Ahmed et al, 1993]. A choke is connected in series with armature to reduce the ripples in the armature current. The time ratio control technique is employed to control the average voltage applied to the armature. The motor torque developed drives the system inertia, friction and load torques. The combined inductance of armature and choke is usually large enough to allow the continuous flow of current in armature circuit.

*Corresponding author: Vijay Kumar Sharma

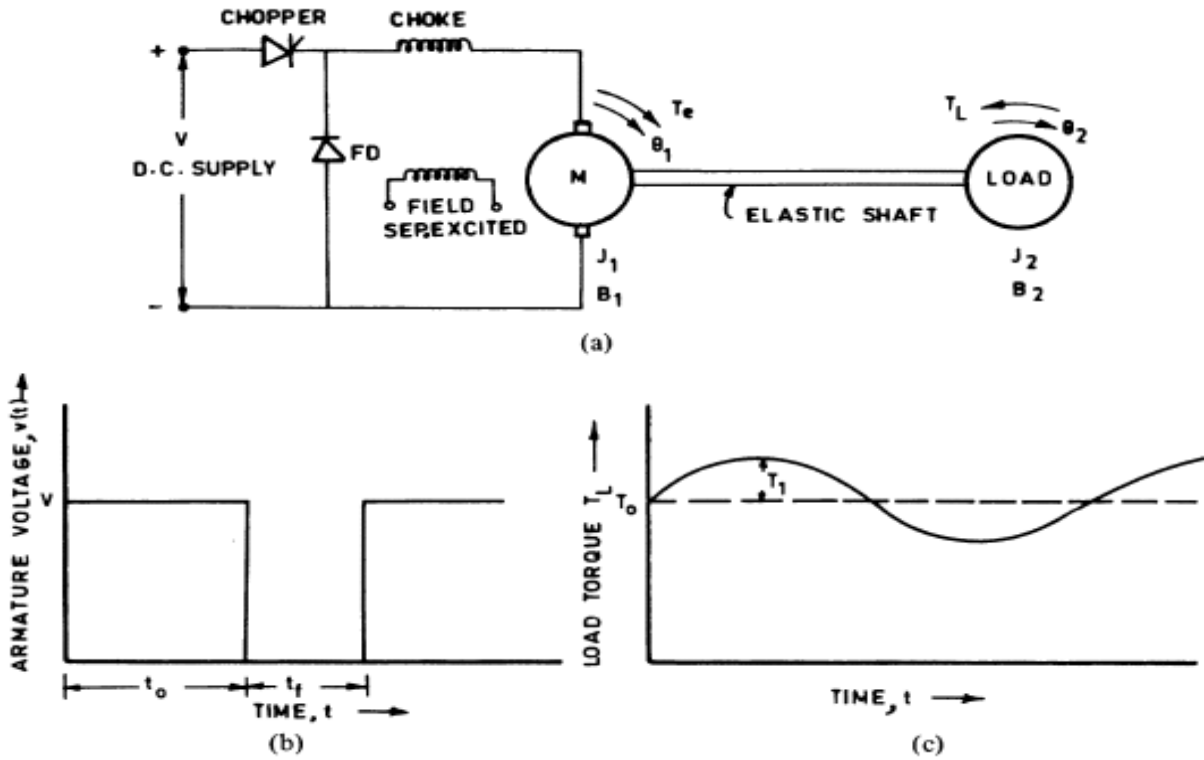

Fig 1 Diagram of a DC drive system

Any periodic load torque can be considered to be composed of a uniform component and several harmonic components. For the sake of simplicity of the analysis, the torque is considered to be composed of a non-varying and fundamental frequency sinusoidally varying component, neglecting other harmonic components.

Mathematical Modeling of the System

The exact mathematical modeling of the system will depend upon the type of motor used and its control. However in general; the equations governing the performance of the system consist of a voltage-current equation of the motor and the dynamic equation of motion as given below:

System equations are given as

$$V = L \frac{di}{dt} + R * i + K_m \dot{\theta}_1 \tag{1}$$

$$T_e = J_1 \ddot{\theta}_1 + B_1 \dot{\theta}_1 + C(\theta_1 - \theta_2) \tag{2}$$

$$-T_L = J_2 \ddot{\theta}_2 + B_2 \dot{\theta}_2 + C(\theta_2 - \theta_1) \tag{3}$$

$$T_e = K_i i \tag{4}$$

where

$$T_L = T_0 + T_1 \sin \omega t \text{ (as load is pulsating)} \tag{5}$$

$$V = V_o \left[\frac{T_{on}}{T_{on} + T_{off}} \right] \text{ (as supply is intermittent)} \tag{6}$$

These equations can be also written in form of state plane equations as follows

$$\dot{x} = Ax + Bu$$

where

$$A = \begin{bmatrix} 0 & 1 & 0 & 0 & 0 \\ -C/J_1 & -B_1/J_1 & C/J_1 & 0 & K/J_1 \\ 0 & 0 & 0 & 1 & 0 \\ C/J_2 & 0 & -C/J_2 & -B_2/J_2 & 0 \\ 0 & -K/L & 0 & 0 & R/L \end{bmatrix}$$

$$B = \begin{bmatrix} 0 & 0 & 0 & 0 & 1/L \\ 0 & 0 & 0 & -1/J_2 & 0 \end{bmatrix}^T$$

$$X = [\theta_1 \quad \dot{\theta}_1 \quad \theta_2 \quad \dot{\theta}_2 \quad i]^T$$

$$U = \begin{bmatrix} V \\ T_L \end{bmatrix}$$

For the system under analysis the values of the circuit parameters as well as mechanical parameters are known. Putting these values in the system matrix the Eigen values are obtained.

Eigen values are the roots of the characteristic equation given as |sI-A|=0.

For the fifth order system the characteristic equation is obtained as

$$A_1 s^5 + A_2 s^4 + A_3 s^3 + A_4 s^2 + A_5 s + A_6 = 0$$

The Eigen values of the system under test conditions given below are calculated as

$$S_1 = -12.5699893 + 7.888014j$$

$$S_2 = -12.5699893 - 7.888014j$$

$$S_3 = 0$$

$$S_4 = -0.08001069 + 519.8234292j$$

$$S_5 = -0.08001069 - 519.8234292j$$

The system undamped natural frequency of oscillations are related to the real and imaginary part of the Eigen values

$$\omega_{n1} = \sqrt{(\alpha_1^2 + \beta_1^2)} \text{ and}$$

$$\omega_{n2} = \sqrt{(\alpha_2^2 + \beta_2^2)}$$

Where,

$$\alpha_1 = -12.5699893 \text{ and } \beta_1 = \pm 7.888014.$$

$$\alpha_2 = -0.08001069 \text{ and } \beta_2 = \pm 519.8234292.$$

The values β_1 refers to the oscillations of damped natural frequency of the system due to electrical parameters. This oscillation mainly depends upon the electrical parameters of the drive such as L and R. Here the damping is more. The values β_2 refers to the oscillations of damped natural frequency of the system due to mechanical parameters. This oscillation mainly depends upon mechanical parameters of the drive such as moment of inertia J_1 and J_2 and damping B_1 and B_2 . Here damping is less. The value of β_1 depends mainly on moment of inertia and armature circuit inductance. For practical systems β_1 is observed to be low and may even vanish for low values of inductance. It is observed that for the case under consideration the value of $\alpha_1 \gg \alpha_2$, where as $\beta_1 \ll \beta_2$. A high value of α_1 is a measure of large damping ratio and due to this reason resonance is not observed at ω_{n1} .

Resonance Condition

The system, under specific operating conditions, exhibits peculiar performance as large peak in armature current and speed are observed. Such a situation arises when the frequency of, at least, one of the two forcing function of the system (supplied voltage and the load torque) approaches the natural frequency of oscillations ω_{n2} . This phenomenon may be referred to as "RESONANCE". The system performance under resonance condition has been studied and various curves are plotted to illustrate this situation. The variation of armature current, speed and twist at different frequencies of load torque and/or supplied voltage is discussed here. For practical D.C. drive system with an elastic shaft under normal operating conditions, torsional oscillations are due to non-rigidity of shaft. These oscillations are of high frequency and low amplitude.

Drive Specifications under Test

Armature resistance, $R = 4 \Omega$
 Armature inductance, $L = 0.16 \text{ H}$
 Moment of inertia, $J_1 = 0.05 \text{ Kg-m}^2$
 Damping coefficient, $B_1 = 0.008 \text{ Nm/rad/s}$
 Torsional stiffness of shaft, $C = 6750 \text{ Nm/rad}$
 Moment of inertia of load, $J_2 = 0.05 \text{ Kg-m}^2$
 Damping coefficient for load, $B_2 = 0.008 \text{ Nm/rad/s}$
 Length of the shaft, $l = 1 \text{ m}$
 Diameter of the shaft, $d = 0.03 \text{ m}$
 Modulus of rigidity, $G = 0.85 \times 10^{10} \text{ Kg-m}^2$

Back emf constant $K_b = 1.86 \text{ V/rad/sec}$
 Torque constant $K_m = 1.86 \text{ N-m/A}$
 Full load current, $I_n = 6.46 \text{ A (1pu)}$
 Rated speed = 1000 rpm (1pu)
 Full Load Torque $T_n = 12.032 \text{ N-m (Calculated)}$

DC drive under normal condition

In this section the analysis of dc motor drives under normal operating condition i.e. other than resonance condition that is, the frequency of any forcing function is not equal to β_2 (resonance frequency due to mechanical parameters of the drive) is presented. A mathematical model of the system is obtained and the system equations are expressed in the state model form. A computer model using MATLAB SIMULINK has been prepared as shown in fig 02, performance of the systems studied, and the curves are obtained. For a typical set of drive system data, the performance in terms of armature current, motor speed and twist in the shaft for the drive is determined in transient as well as steady state condition.

Nature of Voltage applied to Armature

For Chopper Fed DC Supply

$$V = V_0 \left[\frac{T_{on}}{T_{on} + T_{off}} \right]$$

Input Supply voltage,

$$= V_0 T_{on} / T = V_0 T_{on} * f = V_0$$

$T_{on} \cdot \omega / 2\pi$

Where $V_0 = 200 \text{ V}$,

$\omega = 100 \text{ Hz}$ [not equal to β_2 (resonance frequency due to mechanical parameters of the drive) that is 519.82 Hz in given test condition.

$T = T_{on} + T_{off} = 0.06280 \text{ sec}$, $T_{on} = 0.5 * T$ (considering duty cycle to be 50%)

Nature of Load Torque Applied To Shaft

For Pulsating type Load

Pulsating load torque, $T_L = T_1 + T_2 * \sin(\omega_L t + \phi)$

Where;

$T_1 = 0.75 * \text{full load torque} = 9.024 \text{ N-m}$

$T_2 = 0.25 * \text{full load torque} = 3.008 \text{ N-m}$

$\omega_L = \text{pulsation frequency of the load torque} = 100 \text{ Hz}$

$\phi = \text{phase difference of pulsating component of load torque} = 0$

The periodic variation of load torque is assumed to comprise of varying component superimposed on a uniform component. To carry out the analysis, the performance of a d.c. drive system with the above said specifications is analyzed:-

Steady State Armature Current

Fig 3 shows the variation of armature current of dc motor with pulsating load torque and chopper fed DC supply. It is clearly observed that the armature current in steady state is composed of one constant component and other pulsating component.

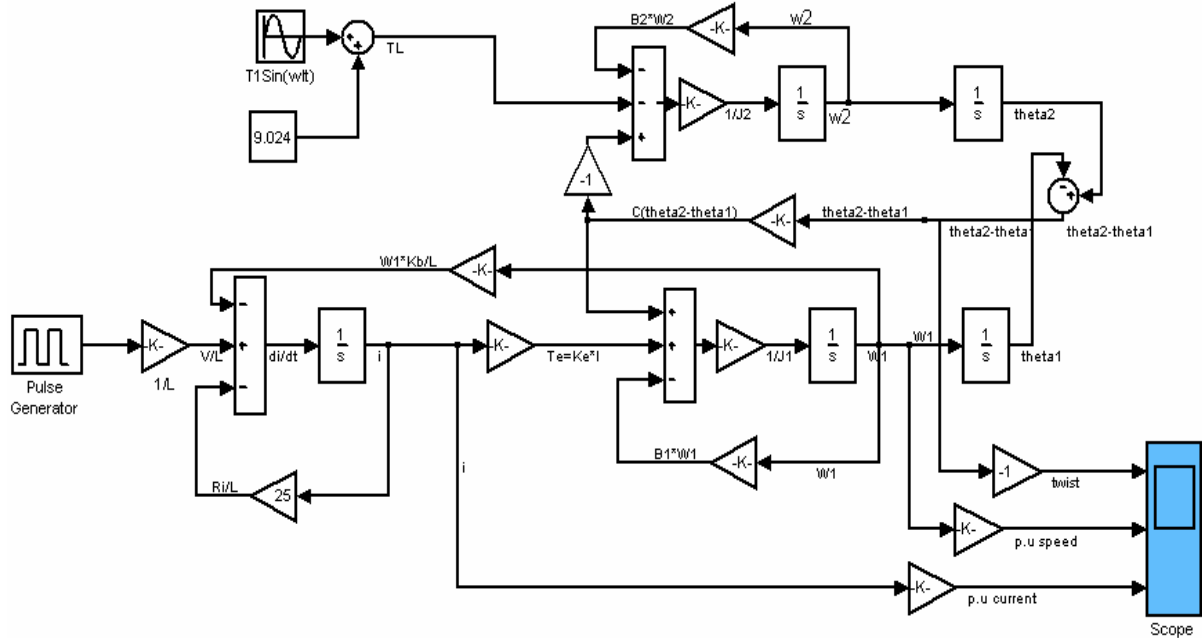

Fig. 2: Simulink model of DC drive with chopper fed DC supply and pulsating load

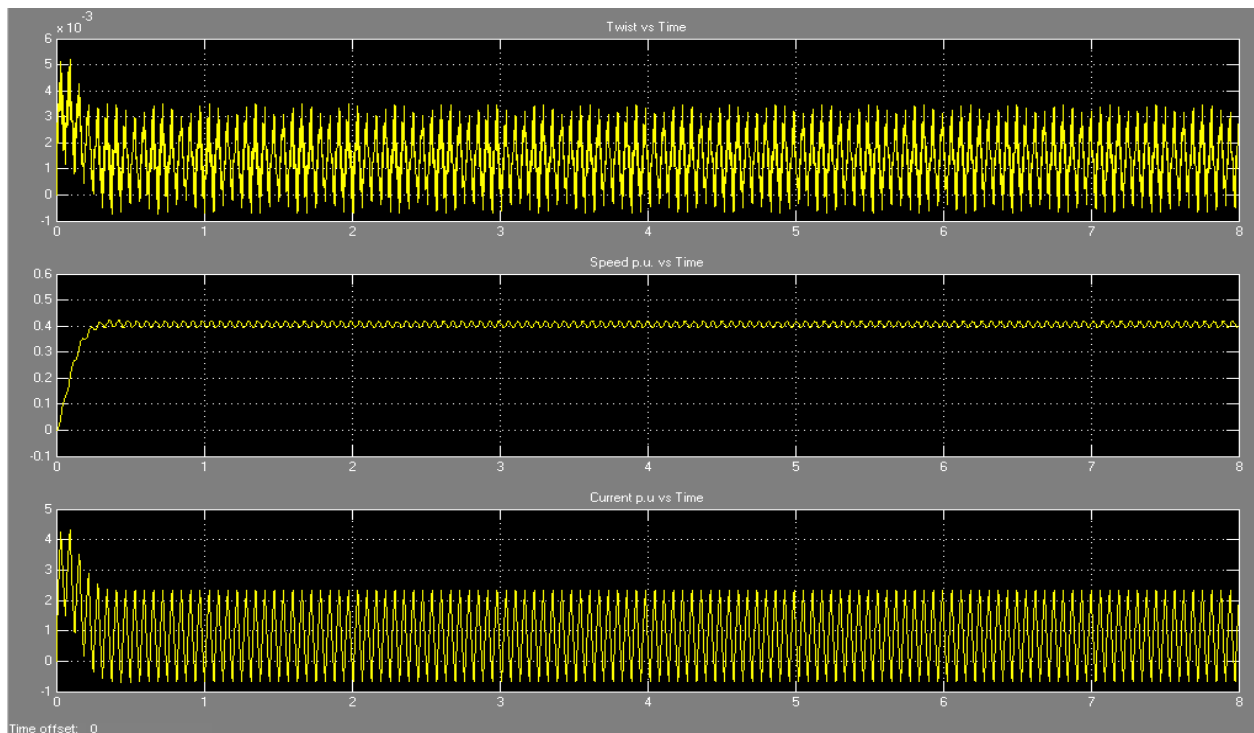

Fig. 3 Variation of Twist, Speed & Armature current under normal running condition

The pulsating component is oscillating with the natural frequency of oscillation. These frequencies of oscillations have come into effect due to the elasticity of the shaft. The maximum and minimum value of steady state armature current is 2.3 pu and -0.7 pu respectively. The average value of steady state armature current is 0.8 pu.

Steady State Speed

Fig 3 shows the variation of speed of dc motor with pulsating load torque and chopper fed DC supply. It is clearly observed that the speed in steady state is composed

of one constant component and other pulsating component. The maximum and minimum value of steady state speed is 0.418 pu and 0.3944 pu respectively. Here the average value of speed is 0.406 pu.

Steady-State Twist in the Shaft

Here in fig 3 we observe that the twist of the shaft is pulsating but its average value is always constant. Its average value is constant under steady state conditions. This average value of the twist is equal to 1.3×10^{-3} radians which produces very small shear stress. The shear stress

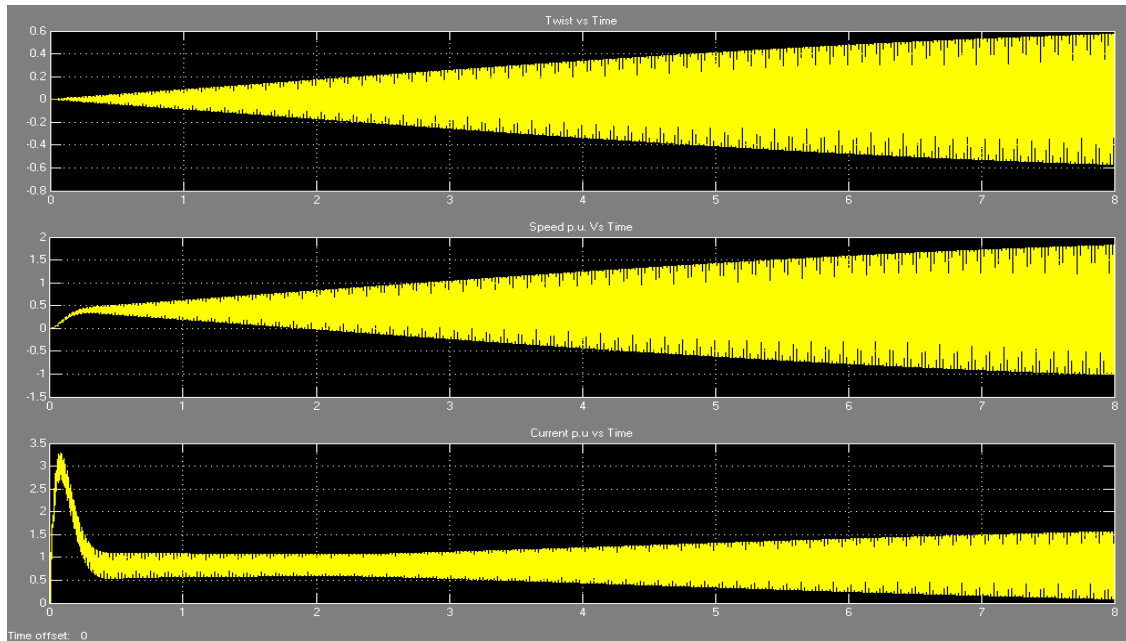

Fig. 4 Variation of Twist, Speed & Armature current under resonance condition

$[Q = G*(\text{twist})*d/2I]$ i.e equal to 66.3 kg/cm^2 . It is under permissible limit in this condition. The maximum and minimum value of steady state twist is $3.4*10^{-3}$ and $-0.8*10^{-3}$ rad.

DC Drive under Resonance Condition

In this section, the analysis of the dc motor with an elastic coupling is presented for a motor fed by a chopper fed dc voltage supply. The supply chopping frequency and pulsating load frequency are observed as the damped natural frequency of an oscillation for the drive system that is β_2 (resonance frequency due to mechanical parameters of the drive). In the given case, $\beta_2 = 519.82 \text{ Hz}$ is taken as the frequency of both forcing functions (supply and load). The effect of elasticity of coupling i.e. torsional oscillation vibration of load torque on the performance of the drive is investigated in fig 04.

Variation of armature current under resonance condition

Fig 04 shows the variation of armature current of dc motor with intermittent load torque under resonance condition. It is clearly observed that armature current is composed of two components. One pulsating and other component is the constant component. The pulsation component is oscillating with the resonant frequency (519.82 rad/sec.) of oscillation. Here it observed that the magnitude of pulsating component of armature current goes on increasing with time.

Variation of speed under resonance condition

Fig 04 shows the variation of speed of DC motor with for intermittent load torque at resonance condition. It is clearly observed that the speed in is composed of two

components. One pulsating and other component is the constant component. The pulsating component is oscillating with resonance frequency of oscillation i.e 519.82 rad /sec and it is increasing in magnitude with the time.

Design of controller

Using the above simulink model, it is found that during resonance, the magnitude of speed, armature current and twist goes on increasing. If these parameters are left unchecked, they may cause damage to the entire drive system. Under resonance condition, the rising twist produces excessive shear stress.

For the tests under study, the twist attains a value of 0.3 at a time of 3.5 sec. The shear stress corresponding to this value of twist is 4653.75 kg/cm^2 which is much greater than the prescribe limit according to the Indian Standard. To protect the system from such an accident, a protective measure is required, for which we have designed a controller.

Here it is desired that the controller must sense the presence and it must be able to cut the supply off. In order to provide safety to the drive system the controller must act little earlier than the instant mechanical failure takes place. For the case under study when $\omega_L = \beta_2 = 519.82 \text{ rad/sec}$, shear stress produces by the twist exceeds the maximum allowable limit at the value twist of 0.3 radians [Rached C et al, 1993]. Therefore the controller is made to operate at the value of twist of 0.15 radians to keep the system safe to remove the resonance we use a controller circuit as shown in fig 05 which consists of three components

(a) Switch (b) Triggered subsystem (c) Data type converter,

Each component has its own importance in the controller process.

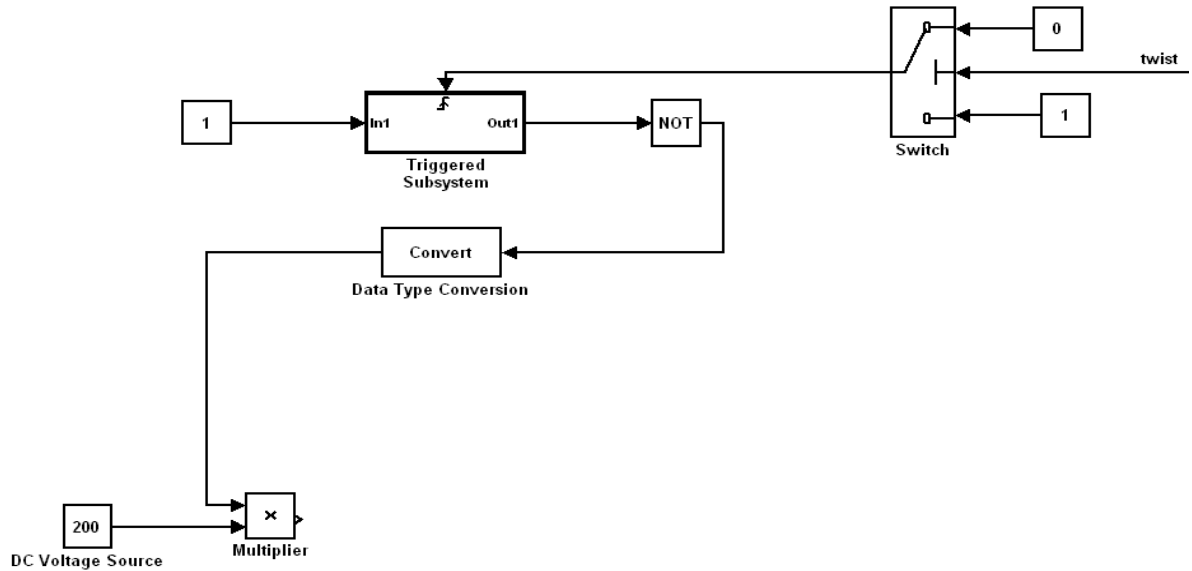

Fig. 5 Controller for DC drive under resonance condition

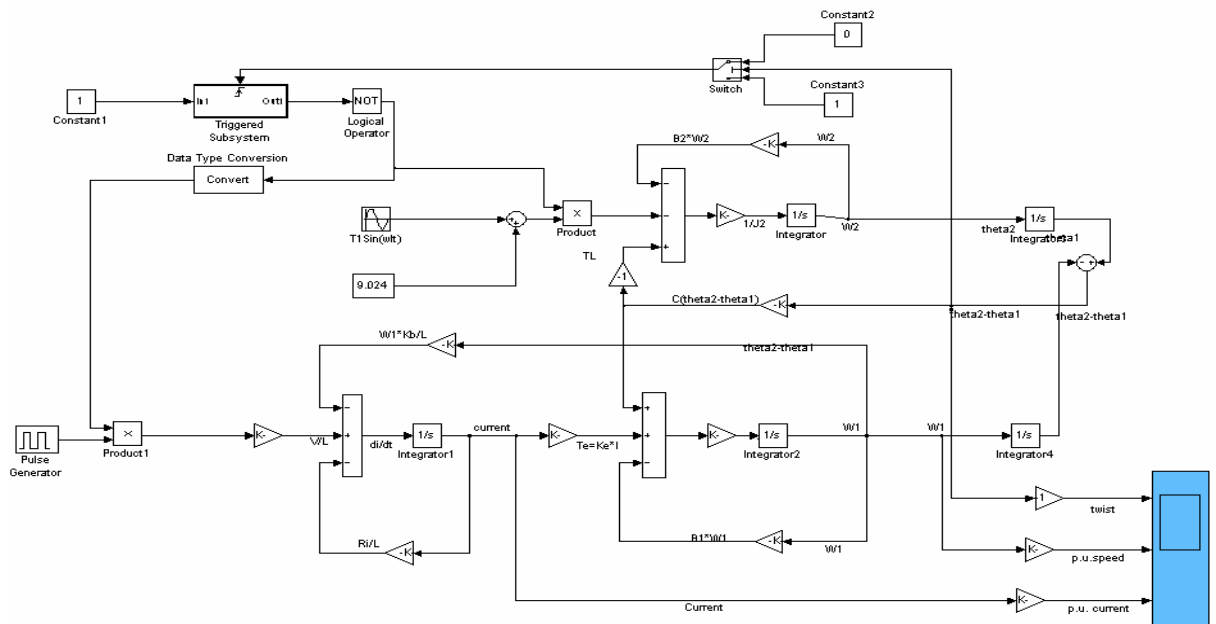

Fig. 6 Simulink model of DC drive for chopper fed DC supply and pulsating load with controller

Switch

Switch is used to sense the resonance condition. When the value of twist becomes greater than a predefined value of twist, drive is operating in resonance condition. The limit is set in such a way that it senses the resonance condition earlier than the twist exceeds the permissible limit. For the system under the predefined value of the twist for the switch 0.15 radians while this exceeds the permissible limit of the Indian Standard at 0.3 radians. The output of the switch is given in the form of 0 or 1 which is used to trigger the trigger subsystem. Output of the switch will be 1 when the input equal to or greater than the permissible limit (0.15 radians) otherwise output will be zero.

Trigger Subsystem

The triggering subsystem is a rising pulse triggering subsystem. When it gets a rising pulse i.e. 1, it is triggered and it passes the input which is coming from the unit block otherwise there will be no effect on the triggering subsystem & output will be zero.

Data Type Converter

The Data Type Conversion block converts an input signal of any Simulink data type to the data type and scaling specified by the blocks Output data type mode, Output data type, and/or Output scaling parameters. Thus when resonance condition occurs and it exceeds the value of permissible limit i.e. 0.2 radians given to the switch block then the output of the switch block is high. This high signal controls the trigger subsystem, it allows to pass the

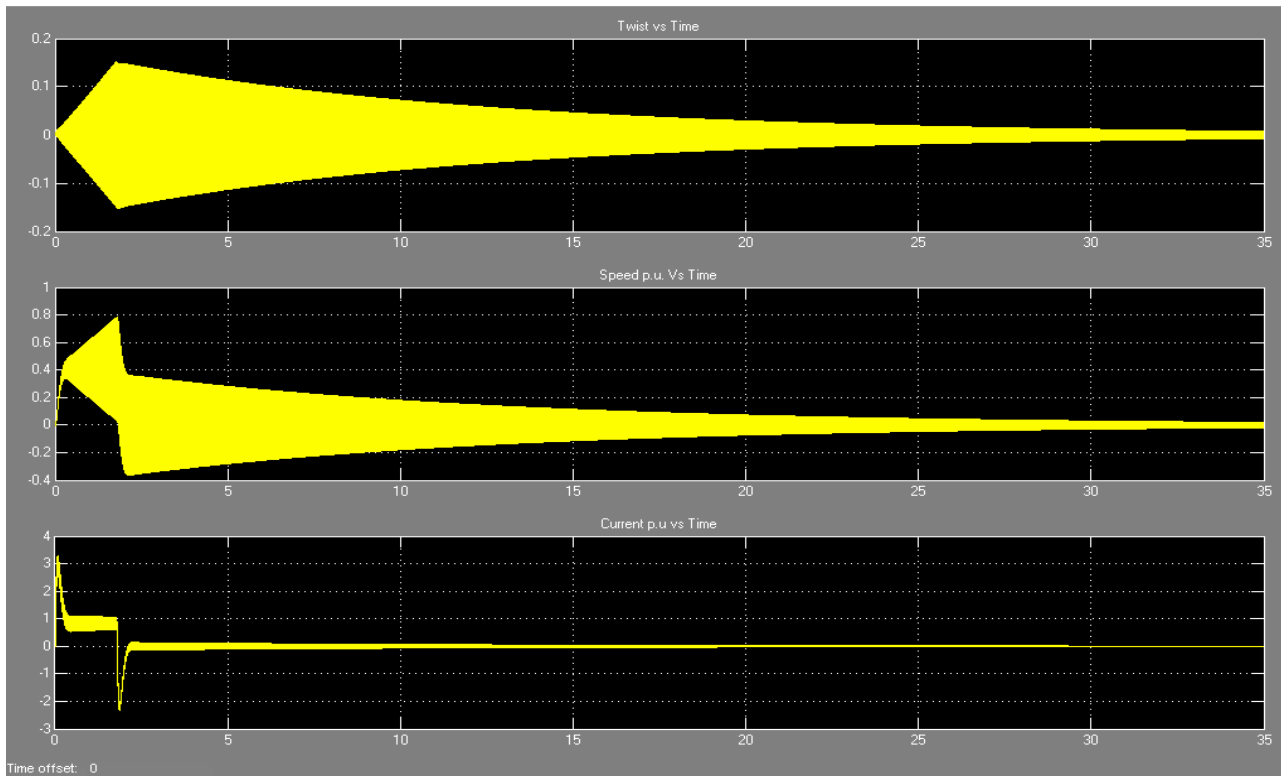

Fig. 7 Variation of Twist, Speed & Armature current with controller

signal from unit block to the NOT block. In this way the supply to the motor becomes zero in order to save the system from harmful effect of the resonance condition.

Variation of armature current under resonance condition (with controller)

Here the variation of armature current with controller under resonance condition is shown in fig 07 here we take the maximum permissible value of twist as 0.15 rad (for example). When the twist exceeds this value, the controller sense this value merely in 1.79 seconds and the supply to the motor becomes off. First the current goes negative because of back emf as the supply off. Then it becomes gradually zero oscillating with a very small magnitude at the natural frequency of oscillation ω_n .

DC drive with controller

Variation of speed under resonance condition (with controller)

The variation of motor speed with controller at resonance condition is shown in fig 07. Here we take the maximum permissible value of twist as 0.15 rad. When the twist exceeds this value, the supply to the motor becomes off. As the supply off the speed starts decreasing and it becomes zero after a short period of time.

Variation of twist under resonance condition (with controller)

The variation of motor twist with controller at resonance condition is shown in fig 07. Here we take the maximum

permissible value of twist as 0.15 rad. When the twist exceeds this value, the supply to the motor becomes off. As the supply becomes off, the twist starts decreasing and it becomes zero after short time.

Conclusion

The performance of a dc drive with chopper fed intermittent power supply and pulsating load torque (periodically varying) for an elastic shaft is obtained. The analysis of above said drive is done for two different conditions (i) normal running and (ii) resonance condition. The analysis of dc motor drives under normal operating condition i.e. other than resonance condition that is, the frequency of any forcing function is not equal to β_2 (resonance frequency due to mechanical parameters of the drive) is observed. For resonance condition, the frequency of any/both forcing functions is equal to the β_2 (resonance frequency due to mechanical parameters of the drive). A Mathematical model of the system is obtained and the system equations are expressed in the state model form. A computer model using MATLAB SIMULINK has been prepared, performance of the systems studied, and the curves are obtained. The following inferences are made from the analysis:

1) For normal running condition, it is clearly observed that the armature current, speed and twist in steady state is composed of two components. One component is constant component while another component is the pulsating component which is superimposed on the constant component. The pulsating component is oscillating with the natural frequency of oscillation. The twist of the shaft

is pulsating but its average value is always constant. Its average value is constant under steady state conditions. This average value of the twist is equal to 1.3×10^{-3} radians producing very small shear stress which is permissible according to Indian standards.

2) For resonance condition, it is clearly observed that armature current, speed and twist go on increasing. This condition is very severe as twist attains very high magnitude of pulsation in very short period of time. It is observed that the twist attains a value of 0.56 radians in short period of time of 8 seconds. It is obvious that the twist is rising at very fast rate at it may exceed the permissible value of twist in very short time and may damage the drive system.

3) Using the controller in the DC drive system, whenever the resonance condition occurs and twist attains the value of twist 0.15 rad, it automatically cut off the supply and hence armature current, speed and twist starting decreasing rapidly and finally reduce to zero in very short time. And therefore drive system remains in safe condition

References

- W.C. Carter, May 1969 Mechanical Factors Affecting Electrical Drive Performance, *IEEE Transactions on Industrial and General Applications*, IGA-5, (3), pp. 282-290.
- J.A. Bishop and C.B. Mayer, March 1979 A Case For High Fidelity Analysis of Non-Linear Electro Mechanical Torsional Dynamics, *IEEE Transactions on Industrial Applications*, IA-15, (2), pp. 201-209.
- C.B. Mayer, Jan. 1981 Torsional Vibration Problems and Analysis of Cement Industry Drives, *IEEE Transactions on Industrial Applications*, IA -17, (1), pp. 81-89.
- D.R. Kohli and S. U. Ahmad, 1981 Performance Analysis of a D.C. Drive Electromechanical System with Elastic Coupling and Pulsating Load Torque, *J. Elect. Mach. Electro. Mech. (U.S.A.)* 6, pp. 541-557.
- G.W. Buckley, Jan. 1980 The Effects of Torsional Elements on the Transient Performance of Large Induction Motor Drive, *J. Elect. Mach. Electro. Mech.*, 5, (1), pp. 53-64.
- D.R. Kohli and S. U. Ahmed, Dec. 1981. Performance of Chopper Controlled DC Drive with Elastic Coupling and periodically varying Load Torque *IEEE Transactions on Industrial Applications*, IA-18, (6), pp.712-727.
- S. U. Ahmed and BR Kohli, 1999 Design and Analysis of Pulse Width Modulated Closed Loop DC Drive: Torsional System Using parameter Clap Plain Technique *Electrical Machines and Power System Journal U.S.A*, 27, (8), pp. 833-848.
- V. Atarod, P L Dandeno, and M. R. Iravani, Nov. 1992 Impact of Synchronous Machine Constants and models on the Analysis of Torsional Dynamics, *IEEE Transactions on Power Systems*, 7, (4), pp.1456-1463.
- Rached C, Kenji Kubo, and Masshiro Tobishe, 1993. Analysis and Compensation of Speed Drive Systems with Torsional loads *PCC- Yokohama*, pp. 272-277.