

Research Article

Real Time Damage Detection System for Structural Health Monitoring of Buildings

Anushri G.Peherkar^{A*} and Vishwashri.A.Kulkarni^A^ADept. of Electronics, Jawaharlal Nehru Engineering College, Aurangabad, Maharashtra, India

Accepted 10 July 2014, Available online 01 Aug 2014, Vol.4, No.4 (Aug 2014)

Abstract

The declining state of civil infrastructure has motivated researchers to seek effective methods for real-time structural health monitoring (SHM). Each structure is unique, therefore the monitoring system that must be applied is also singular. Civil infrastructures, are an essential part of our social life, and thus represent critical systems that need constant and careful monitoring. Which must be protected against cooling failures by providing necessary monitoring tools and alerting mechanism to the administrators. A wireless sensor network is proposed for monitoring buildings to assess damages. This paper discusses both hardware and software development aspects to achieve the desired goal. This study explores the development of a versatile sensor board with on board signal processing. The sensor board is mounted at every floor of the building Cheap nodes able to monitored information about Temperature, Humidity and also abnormal vibration of the building due to natural disaster or heavy construction work around the structure, They measure periodically or on demand from the base station. This system also has an alarm alerting provision whenever the sensed parameters go beyond the preset threshold values A low power network architecture was implemented over an 802.15.4 MAC in the 900-MHz band to transfer sensed parameter data to base station. Database, as storing the data off site for post-processing and further analysis. To this end provide a custom graphical user interface. The information can be used for a rapid building safety assessment, and to support decisions for necessary repairs, replacements and maintenance and rehabilitation measures.

Keywords: Structural health monitoring, Abnormal vibration, Temperature, Humidity, Base station

1. Introduction

As new materials and technologies are discovered, buildings gets taller, bridges get longer spans and the designs of structures become more ambitious, but more complex. In view of these developments, there is an increased requirement to providing both the costs savings with regard to maintenance and a safer environment for by preventing structural failures. Civil infrastructures, such as bridges or public buildings, are an essential part of our social life, and thus represent critical systems that need constant and careful monitoring.

The cost of repairing/rebuilding and the immeasurable cost of human lives are two very valid reasons that structural designs must account for these disasters. Structural health monitoring (SHM) is a process aimed at providing accurate and in-time Information concerning structural condition and performance on a proactive basis. It consists of permanent continuous, periodic, periodically continuous recording of representative parameters, over short or long terms. The information obtained from monitoring is generally used to plan and design maintenance, increase the safety, verify hypotheses, reduce uncertainty and to widen the knowledge concerning

the structure being monitored. In spite of its importance, the culture on structural monitoring in world is not yet widespread.

The important aspects are responses in the structure. Responses which can be commonly measured can be in general divided in

Mechanical: Strain, Deformation, displacement, cracks opening, stress, load

Physical: Temperature, humidity, pore pressure

Chemical: Chloride Penetration, sulphate penetration, pH, rebar oxidation, steel oxidation.

Due to an abnormal amount of vibration there is a need to control the action of building, at the time the earth quake occurs. If earthquakes only moved the ground vertically, buildings might suffer little damage because all structures are designed to withstand vertical forces those associated with gravity to some extent. But the rolling waves of an earthquake exert extreme horizontal forces on standing structures. These forces cause lateral accelerations, which scientist's measure as G-forces. Such a sudden movement to the side creates enormous stresses for a building's structural elements, including beams, columns, walls and floors, as well as the connectors that hold these elements together. If those stresses are large enough, the building

*Corresponding author: **Anushri G.Peherkar**

can collapse or suffer crippling damage. There is need to understand the three concepts namely vibration of ground and building during an earth quake, design of building to withstand an earthquake and response of the building (j.paek,k.chintalapudi et al, 2005). To monitor a building in real time, it should be checked for various numbers of parameters like vibration, temperature, load etc. One of the most important parameter to be monitored in real time building is the amount of moisture content in clay bricks. High moisture content can promote its deterioration. In general, most chemical and physical corrosion process occurs due to the high moisture content that leads to the damage of buildings (lynch, j.p loh,2006).

There are many different SHM techniques under research, but this paper focuses on two types: damage detection through global vibration measurements and through wave propagation. Vibration testing usually involves two types — forced and ambient vibrations. In forced vibration, actuators apply forces on the building to cause vibration. Sensors then measure the building movements to identify damage. Shakers and impact hammers are typically used for harmonic and impact excitations, respectively. In ambient vibration, building movement is caused by surrounding activities such as wind, nearby traffic, mechanical operation within the building, etc.

All buildings experience ambient vibration constantly. The advantage of ambient vibration over forced vibration is that the former does not artificially affect any building operation; forced vibration causes larger movements that may interfere with building operations. However, because of the small movements by ambient vibration, sensors need to be more sensitive to measurement noise. This paper evaluates the Propose system of a ZigBee-based wireless network under multihop transmission over an extended period of time. Totally, five sensor nodes are deployed on four corners of the building. sensors sensing data continuous and stored it into the buffer. One of the nodes is a coordinator, and all the others are sensors with the routing capability. Each sensor regularly transmits packets to the coordinator during a long-term operation time. A selected number of monitoring nodes exceeds a certain minimum threshold, during a certain minimum time; these monitoring nodes alert the base station which will decide whether to wake up the alarm of acceleration sensing nodes over the radio. The end device which can work together with the control unit. The end device sends the sensor information to the control unit from time to time. Once the sensor message is received by the end device, it stores the sensor message into its database. On the other hand, It provides webpage based graphical presentation of the sensor data.

The remainder of the paper is organized as follows. Section II presents the considerations that motivated our work. The architecture of the whole system is described in Section III, and section IV Propose system. Section V the scenario is presented, together with a discussion on the results of the tests carried out to validate the prototype platform. Section VI advantages. Finally Section VII reports our conclusion and gives some directions on the on-going work.

2. Literature Survey

Aktan et al., 1998 were amongst the first to introduce objectives for and components of an intelligent monitoring system. One of the main components identified is the communication interface.

For comparison and structural understanding, quantifiable metrics for reliability and health are recommended and a generalized theory can be developed (Aktan et al., 2000a, Pines and Aktan, 2002). Both metrics and a generalized theory can be developed when a sufficient amount of monitoring results are present, but non-destructive evaluation and controlled testing also provide some of the required information

Farrar and Lieven, 2007 mention that identifying the presence and quantifying the extent of damage is a critical component of structural health monitoring. One of the main issues is the lack of historical data and knowledge of structural responses, in particular damage mitigation.

Wenzel, 2009 suggests that a SHMS is an integrated decision support system, mainly focused on the users and the availability of data. Such a SHMS may contain a display embedded in a GIS environment reporting the status of the structure.

Due to these challenges and the importance of displacement measurements, applications of SHM using global positioning systems(GPSs),(T.sun,N.C.liang,2007), laser Doppler vibration (lynch,J.P2006)), terrestrial laser scanners and vision-based methods(Sladek,a2007, Moschas,2011),Radiofrequency Identification (RFID) tags, laser displacement sensor (LDS) as a non-contact measurement device to directly measure the displacement of a structure and developed a wireless laser displacement measurement system using a customized wireless sensor node mounted as well as existing displacement transducers have been proposed as potential methods of displacement measurement. However, these techniques cannot satisfy all of the requirements of cost effectiveness, accuracy, long-term measurement, and real-time monitoring when SHM is applied to real structures.According to International Society of Structural health Monitoring and Intelligent Infrastructure (ISHMII) lot of bridges and structures have been installed with sensors and are monitored for any damage in European countries (G.hackman,2008)

Adding to the fact that the cost of traditional wire-based monitoring systems is driven by the number of sensors, the installation time and installation costs limit the scale of deployment of such systems (Lynch et al.2006).From experience, the installation time of a structural monitoring system for bridges and buildings can consume over 75% of the total testing time, and the installation labour costs can approach well over 25% of the total system cost (Lynch et al. , 2000). These installation time and device costs can be greatly reduced via Micro-Electro-Mechanical Systems (MEMS) based sensors integrated in Wireless Sensors Networks (WSN). In this line, the recent years have witnessed an increasing interest in a new technology based on WSN platforms as a low-cost alternative for being applied in civil engineering structures (Lynch et al. , 2006).Recent work has demonstrated the feasibility of continuous structural data

collection using an inexpensive wireless sensor (Lynch and Loh, 2006). Although a wireless sensor network is able to cut the wiring cost, wireless channels typically have lower bandwidth compared to wired channels because wireless communication lacks a dedicated medium where transfer rate and data delivery are more reliable. Therefore, bandwidth becomes a larger concern for wireless sensors.

The design of the SHMS can be divided into the following components (Brownjohn, 2007):

1. Sensors
2. Data storage
3. Data transmission
4. Database management
5. Data mining (for feature extraction)
6. Load/effect model development
7. Heuristics (learning from past experiences)
8. Decision making
9. Reporting

Although Brownjohn, 2007 only lists the first 8 components, the last component is added for the benefit of the user. This is also the only component which interfaces the SHMS with the end-user, and until recently (Wenzel, 2009) has commonly been omitted.

3. System Overview

Systems for SHM must typically include a sensory and data acquisition subsystem, some mechanism for data gathering and storage, and finally a data analysis subsystem, where the structural model is computed and update, and general structural conditions may be assessed at a higher level of abstraction. "Figure.1" shows a functional description of our system architecture through its composing blocks; in particular, two separate and functionally different, sets of sensor nodes may be identified, as well as a collecting device where part of the low-level data processing is conducted, a temporary storage device, and a remote database.

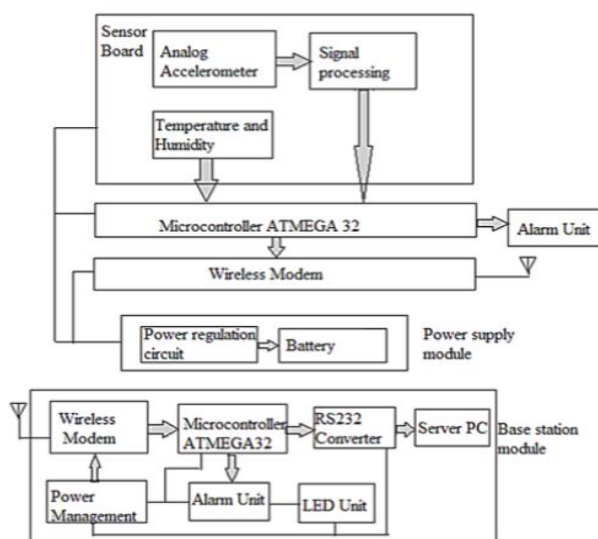

Fig.1 A schematics description of the architecture of the proposed system

According to the project requirements, main phenomena needed to be monitored, each imposing different functional requirements as reflected by the architectural schema.

A. Accelerometer module

To measure vibration we used an analog, ultra-compact, tri-axial acceleration The MMA7361L is a low power, low profile capacitive micro machined accelerometer integrated on a sensor board featuring signal conditioning, a 1-pole low pass filter, self-test 0G-detect liner freefall. Analog output for each axis, Selectable Sensitivity (1.5g,6g), high sensitivity 800mv/g@1.2g detect for free fall detection.

(S.C.Mukhopadhyay,2011)Sensing parameter is store into the buffer. We computed calibration coefficients for each sensor with induced vibrations at different frequencies and amplitudes using a shake table and piezoelectric accelerometers for seismic vibrations. Sensing parameter store into the buffer.

B. T-H module

The DHT11 is a basic, low-cost digital temperature and humidity sensor integrated on a sensor board. It uses a capacitive humidity sensor and a thermistor to measure the surrounding air, and spits out a digital signal on the data pin. Its small size, low power consumption and up-to-20 meter signal transmission. The sensor measurement range is 20-30%RH and 0-50 deg c. The sensor features is Calibrated digital signal, Outstanding long-term stability. Each DHT11 element is strictly calibrated in the laboratory that is extremely accurate on humidity calibration. The calibration coefficients are stored as programmes in the OTP memory, which are used by the sensor's internal signal detecting process. Communication Format can be separated into three stages: Request, Response, Data Reading. Sensing parameter store into the buffer.

C. ZigBee Hardware Design.

The Zigbee node hardware adopts a 8-bit RISC processor ATMEGA 32 Several integrated peripherals including timers, counters, 10-bit AD converter, USB, UARTs, LCD controllers, , controller area network (CAN) interfaces, pulse- width modulation(PWM), and JTAG for debugging are built around the processor. The external memory comprises an in- system programmable Flash ROM (16MB) and an SDRAM (16MB). To implement a visual user application interface, ZB32 provides four buttons and five LEDs. An IEEE 802.15.4 compliant RF transceiver, is connected to an on-board 2.4GHz chip antenna and to one of the serial peripheral interfaces of the processor. The sensing module, where several sensors are supplied for detecting environment conditions (such as temperature, humidity, and light). For general-purpose development, a prototype area is provided for other extended sensing functions. In addition, a sounder which could be used as an alarm notifications also available. About the energy source, the ZBnode can be powered with an AC adapter or

battery with a DC input range from 3.5 to 5.5V.(cerootti,m2009)

D. Base station module

This module consist Zigbee receiver, microcontroller and alarm unit and Data storage unit .LED unit contain two different colors led i.e red and green. The ZigBee RF Modules are designed to operate within the ZigBee protocol and support the unique needs of low-cost, low-power.The modules require minimal power and provide reliable delivery of data between remote devices. The modules operate within the ISM 2.4 GHz frequency band.Its give Indoor/Urban up to 133’ (40 m) ,Outdoor line-of-sight up to 400’ (120 m) and Transmit Power is 2 mw Receiver Sensitivity is 96 dBm, and also give High Performance, Low Cost.

4. Working Operation

Figure 2 represents such a flowchart. Excitation is the only input of the system, acting on the structure (top left). Together with the sensors and data acquisition, these blocks represent the monitoring aspect. The processing and evaluation following data acquisition generate the parameters required to continue the assessment. It is possible that after evaluation, thresholds are set for certain parameters and these can form the basis for issuing an alarm. Often model updating and simulations are needed to generate a complete overview of a structure’s condition. Based on the condition of the structure, again alarms can be issued but more advanced decisions like maintenance can now be made. Finally with these results, feedback to update theories and designs can be also be extracted.

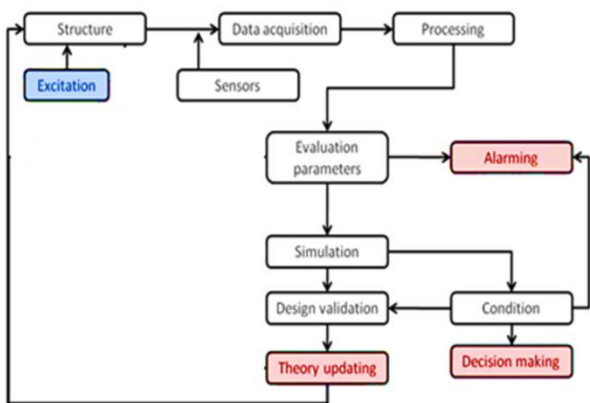

Fig. 2 Processes needed to achieve the objectives of a full structural health monitoring system

Node Connectivity :In our work, if a node can send out packets to the coordinator within a specified period of time, the node is defined as “connected.” Otherwise, the node is “disconnected.” Obviously, if more nodes in a sensor network are connected, the network is more stable. Accelerometer and T/H module measurement the acceleration and temperature humidity continuously and store it into the buffer. The acquired data was transmitted to the base station using wireless communication, as When

requisite was formed by base station. When the measurement beyond the predefined threshold will be seen as “high dynamic stress, so the action to be taken in response to an event with alarm form both sending and receiving side. The value measured by different sensor at different time intervals are saved into the table1.Table 1 summarizes the results of the experimental modal identification studies performed in the pendulum.

Data visualization and access: Effective access to the information gathered by the system is crucial in supporting the structural engineers in their analysis. To this end, we provide a custom graphical user interface, shown in Figure 3, implemented through a major re-factoring of Octopus (Moschas,2011). The GUI shows the current network topology and serves as a control center from which the user can remotely task the sensor network. The original data, together with higher-level information generated by such models, is made available to the end user that do not just provide a view of collected data, but also allow users to obtain more elaborated information, and to modify the system’s behavior it shows information on the sensing parameters (sampling rate, thresholds), history of past monitoring activities, view of current monitoring (measurements ordered by sensor type, etc.), view of current and past events with start and finish time consist of year, month, day and hour and minute as shown in fig.5 Moreover, it displays the data collected, which are also persistently stored in a database.

5. Experimental scenario and results

The results of the tests carried out to validate the prototype platform.”Figure3” below shows the connection diagram for the test setup.

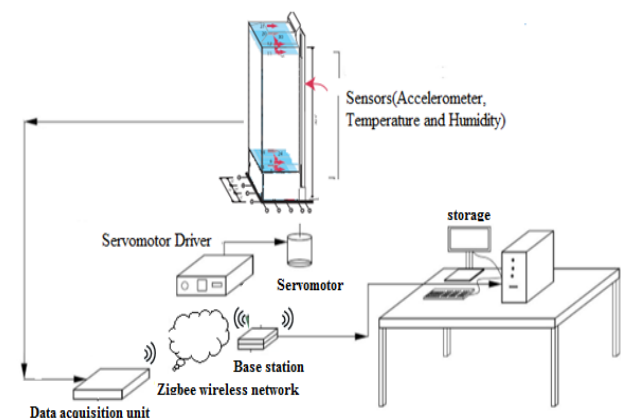

Fig.3 A schematic representation of the actual deployment.

Here is the data acquisition system hardware and base station is the software to control the permanent shaker to excite the system and Data acquisition system which is used for both, generating the excitation signal and measuring the response. Signal conditioner is used as power supply to the sensors’. A excitation signal is generated from the base station and sent to the amplifier which is used to supply power to the shaker and also to amplify the signal. From the amplifier the signal is sent to

the shaker which is connected to the building with a rod. The shaver starts vibrating causing the building to vibrate and the accelerometers placed on the building will measure the vibration. The measured vibration is passed through the signal conditioner to the base station. From base station it is then transferred to computer by a mini USB cable.

The first test was aimed to observe the quality of the time series recordings of the developed platforms. With this an impulse force was registered using accelerometer and one new sensing node, located at the top of the building . The tests were a sampling rate of 100 Hz and sampling time 10 sec, results are shown in figure 4 .

Table 1 Modal Identification Results

Time	x	y	z	temp	Humidity
10	233	266	301	36	38
20	232	267	303	36	38
30	234	266	301	36	39
40	234	267	302	36	38
50	213	246	280	36	38
60	233	265	303	36	39
70	234	265	321	36	38
80	233	265	303	36	38
90	232	266	301	36	39
100	234	264	302	36	38
110	235	265	300	36	38
120	234	266	302	36	39
125	235	267	301	37	38

Table.1 summarizes the results of the experimental modal identification studies performed in the building using the conventional systems and new sensor network platforms

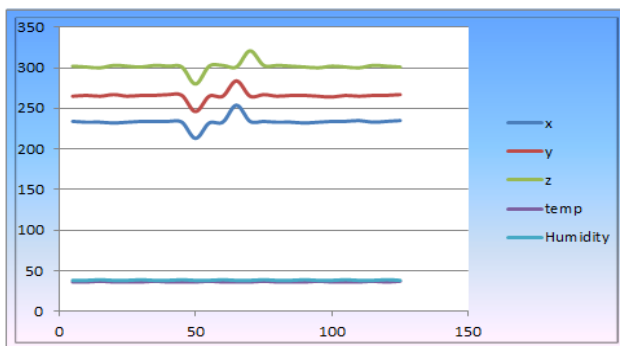

Fig. 4 Experimental modal analysis results

Figure 4 is the screen cut of the monitoring function from the main server. There are five curves in the diagram representing temperature and humidity respectively and accelerometers x ,y, z axis . As shown in Fig.5, the Control command interface and the Data monitoring interface, provides the window application to the end user to issue control command and monitor data. The data monitoring results and the control user interfaces can be observed

from the graphical interface. It also shows the start and finish time of monitoring. People can also compare the temperature or humidity by selecting different sensors in the list box.

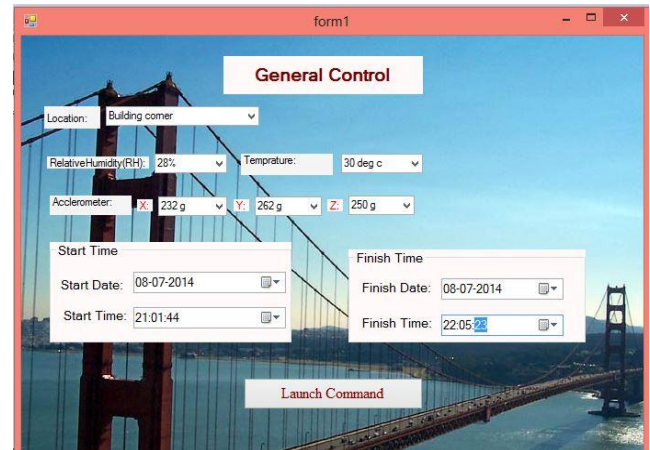

Fig 5 Control function user interface of the web service

6. Advantages

1. Promote a new concept of civil engineered smart structures conceived and designed as high performance systems
2. Help to enter the large building market.
3. Offer an integrating solution towards sustainability
4. Act as a catalyst for new high-tech sensing systems.
5. Complex Structures are well managed.
6. Monitoring reveals hidden resources.
7. Rapid assessment of building’s health
8. Reliable data on actual condition of structure
9. Detect early signs of failure
10. Protect integrity of property and lives
11. Optimize insurance and maintenance costs

7. Future Work and Conclusion

The presented wireless system for building monitoring takes advantage of the unique features of custom-developed sensors and mesh network module architecture, to realize a solution which offers potentially low cost in manufacturing, installation and maintenance, while providing high-quality sensor data at the right time. The system records accelerations and computes displacements (and drift ratios) also temperature, humidity in near real-time. The variable drift ratio is related to the damage and safe occupancy criteria of the specific building. It utilizes the database technology to increase the duplicity of the system and also implement the buffer mechanism to handle the situation when the connection is lost. This allows users to interact with the system, not just to view the collected data, but also to modify its behavior in order to tune it to the specific, and dynamically changing, requirements.

Though this proposed method illustrates ZigBee based wireless transmission, it is necessary to speed up the data transmission and for portability. So the advancement of technology includes the designing of web server. With the

concept of earth quake alert system it is need to make loss assessment after an earth quake. Then, damage detection system, is need to update the location where the damage presents.

Acknowledgement

There are countless individuals that deserve my sincere gratitude for helping me to complete this work .First and foremost, I would like to express my sincere gratitude to my respected project Guide, Prof.V.A.Kulkarni for her invaluable guidance and help.

References

- K. C. Park and G. W. Reich(2000), Model-based health monitoring of structural systems: progress, potential and challenges, in Proceedings of the 2nd International Workshop on Structural Health Monitoring. *CRC Press*, pp. 82–95.
- J. Paek, K. Chintalapudi, R. Govindan, J. Caffrey, and S. Masri,(2005) A wireless sensor network for structural health monitoring: Performance and experience, in Proceedings of the 2nd IEEE workshop on Embedded Networked Sensors. *IEEE*, , pp. 1–9.
- G. Hackmann, F. Sun, N. Castaneda, C. Lu, and S. Dyke, (RTSS 2008).A holistic approach to decentralized structural damage localization using wireless sensor networks, in Proceedings of 29th IEEE *Real-Time Systems Symposium* IEEE, 2008.
- Giuseppe Anastasi, Giuseppe Lo Re, and Marco Ortolani. (2009)WSNs for Structural Health Monitoring of Historical Buildings in proceeding of the human system interaction HSI 2nd conference on digital object identifier IEEE,2009
- Cerriotti,m;gunna,s,(2009)Monitoring heritage with wireless sensors networks:the torre Aguila development in proceeding mpf *the information processing in sensors networks* ,IPSN2009.
- M.J. Chae , H.S. Yoo,J.Y. Kim , M.Y. Cho, (2012,)Development of a wireless sensor network system for suspension bridge health monitoring, see front matter *Elsevier*, vol. 21, pp: 237-252.
- J.M. Ko, Y.Q. Ni,(2005) Technology developments in structural health monitoring of large-scale bridges, see front matter *Elsevier Ltd*, Vol. 27, , pp: 1715-1725.
- M. C. Rodríguez-Sánchez, S. Borromeo, Member, IEE, E, and J. A. Hernández-Tamames (2011)Wireless Sensor Networks for Conservation and Monitoring Cultural Assets in proceeding of *IEEE sensors journal*, vol. 11, no. 6.
- S.C.Mukhopadhyay, I.Ihara (2011)Sensors and technologies for structural health monitoring :a review New Developments in Sensing Technology for Structural Health Monitoring *Lecture Notes in Electrical Engineering Volume* 96, , pp 1-14
- T. Sun, N. C. Liang, L. J. Chen, P. C. Chen, and M. Gerla, (2007) Evaluating mobility support in ZigBee networks embedded and ubiquitous computing, in Proceedings of the International Conference on Embedded and Ubiquitous Computing (EUC'07), vol. 4808 of *Lecture Notes in Computer Science*, pp. 87–100, *Springer*.
- Doebling, S.W., Farrar, C.R., Prime, M.B., and Shevitz, D.W., (19980)A Damage Identification and Health Monitoring of Structural and Mechanical Systems from Changes in their Vibration Characteristics: A Literature Review, *Los Alamos National Laboratory Report* LA-13070-MS.
- Yuan, S., Lai, X., Zhao, X., Xu, X., and Zhang, L., (2006). Distributed Structural Health Monitoring System Based on Smart Wireless Sensor and Multi-agent Technology, *Smart Materials and Structure*, 15, 1–8.
- Lynch, J.P., and Loh, K.J., (2006). A Summary Review of Wireless Sensors and Sensor Networks for Structural Health Monitoring, *The Shock and Vibration Digest*, 38(2), 91-128.
- Miyashita, T.; Nagai, M.(2008) Vibration-based structural health monitoring for bridges using laser doppler vibrometers and MEMS-based technologies. *Int. J. Steel Struct.* , 8, 325–331.
- Sladek, J.; Ostrowska, K.; Kohut, P.; Holak, K.; Gaska, A.; Uhl, T.(2007) Development of a vision based deflection measurement system and its accuracy assessment. *Measurement* 2013, 46, 1237–1249. 17.
- Lynch, J.P. An overview of wireless structural health monitoring for civil structures. *Philos. Trans. R. Soc. A*, 365, 345–372.
- Moschas, F.; Stiros, S.(2011) Measurement of the dynamic displacements and of the modal frequencies of a short-span pedestrian bridge using GPS and an accelerometer. *Eng. Struct.* , 33, 10–17. 10.
- Park, H.S.; Sohn, H.G.; Kim, I.S.; Park, J.H.(2008) Application of GPS to monitoring of wind-induced responses of high-rise buildings. *Struct. Des. Tall Spec. Build.* , 17, 117–13
- <http://www.bartleet.ucl.ac.uk>
- <http://unesco.org>.